

NOTES:

REV.		DESCRIPTION		DATE	APPROVED
A		FULL RELEASED		MAR 8, 2024	DUKE

DETAIL A
SCALE 1:1

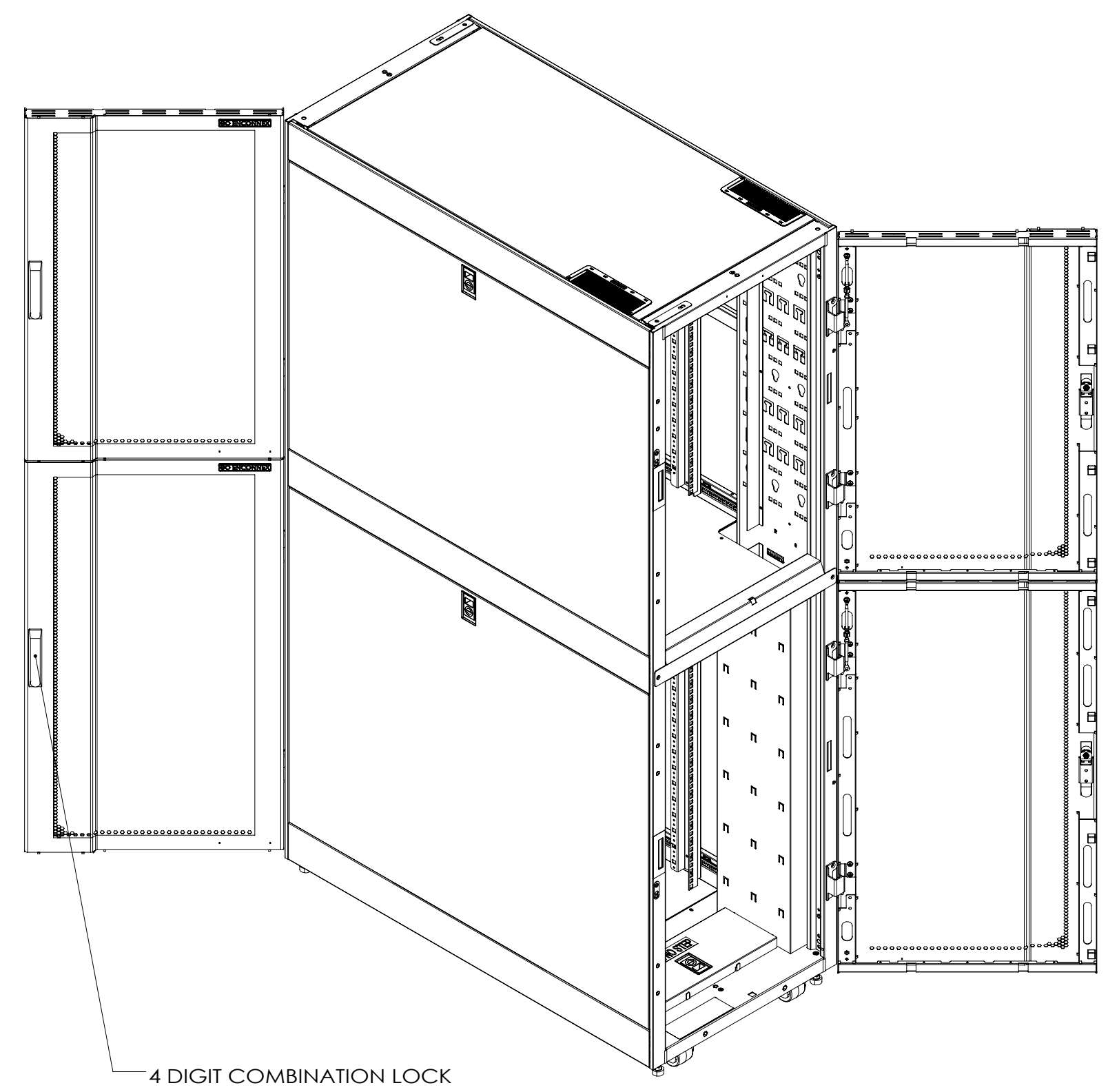
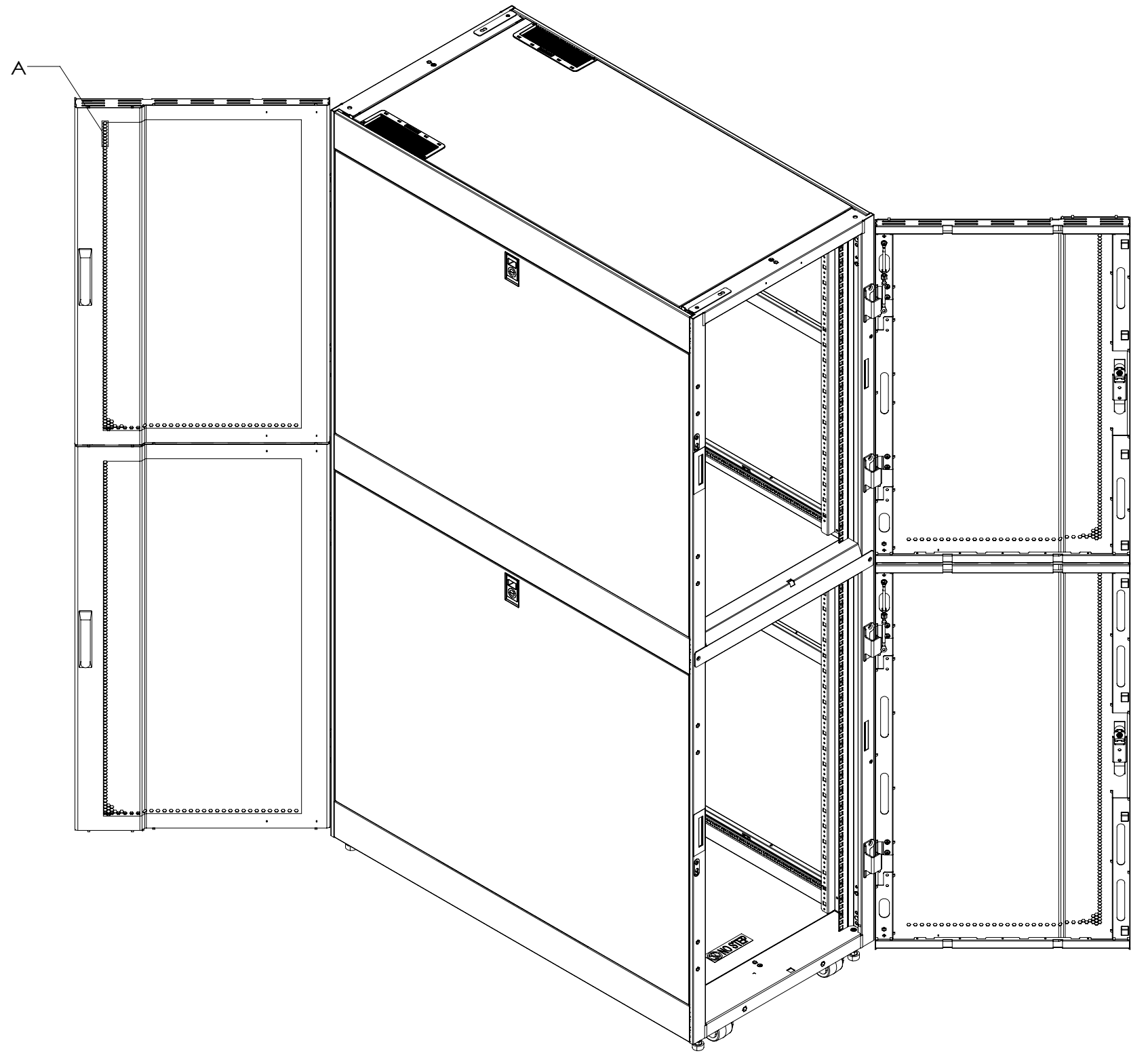
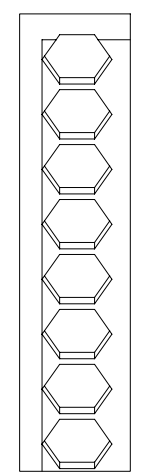

4 DIGIT COMBINATION LOCK

<p>PROPRIETARY AND CONFIDENTIAL</p> <p>This drawing and its specifications are the property of ENCONNEX and shall not be copied, reproduced, or used in whole or in part, as the basis for the manufacture or sale of items without written permission from ENCONNEX. This drawing is based upon the latest available information and is subject to change without notice.</p>	<p>UNLESS OTHERWISE SPECIFIED</p> <p>X = ± 1 X.X = ± 0.5 X.XX = ± 0.30 X.XXX = ± 0.130 ANGULAR X = 1° X = 0.5° .XX = 0.25°</p>		<p>4670 AIRCENTER CIRCLE RENO, NV 89502</p>	<p>DESCRIPTION:</p> <p>INFINIRACK MULTI-BAY, 600X1200, 20UX23U</p>																						
	<p>COMMENTS:</p>			<p>MATERIAL: SEE INDIVIDUAL</p>																						
<p>UNITS: in [mm]</p>	<table border="1"> <tr> <td>NAME</td> <td>DATE</td> </tr> <tr> <td>YIFEI</td> <td>MAR 8, 2024</td> </tr> <tr> <td>DUKE</td> <td>MAR 8, 2024</td> </tr> </table>	NAME	DATE	YIFEI	MAR 8, 2024	DUKE	MAR 8, 2024	<table border="1"> <tr> <td>FINISH:</td> <td>CLASS:</td> </tr> <tr> <td>N/A</td> <td>N/A</td> </tr> </table>	FINISH:	CLASS:	N/A	N/A	<table border="1"> <tr> <td>SIZE:</td> <td>DRAWING NO:</td> <td>REV NO:</td> </tr> <tr> <td>C</td> <td>E011200-01X</td> <td>A</td> </tr> </table>	SIZE:	DRAWING NO:	REV NO:	C	E011200-01X	A	<table border="1"> <tr> <td>SCALE:</td> <td>WEIGHT:</td> <td>SHEET:</td> </tr> <tr> <td>1:12</td> <td></td> <td>1 OF 3</td> </tr> </table>	SCALE:	WEIGHT:	SHEET:	1:12		1 OF 3
NAME	DATE																									
YIFEI	MAR 8, 2024																									
DUKE	MAR 8, 2024																									
FINISH:	CLASS:																									
N/A	N/A																									
SIZE:	DRAWING NO:	REV NO:																								
C	E011200-01X	A																								
SCALE:	WEIGHT:	SHEET:																								
1:12		1 OF 3																								

NOTES:

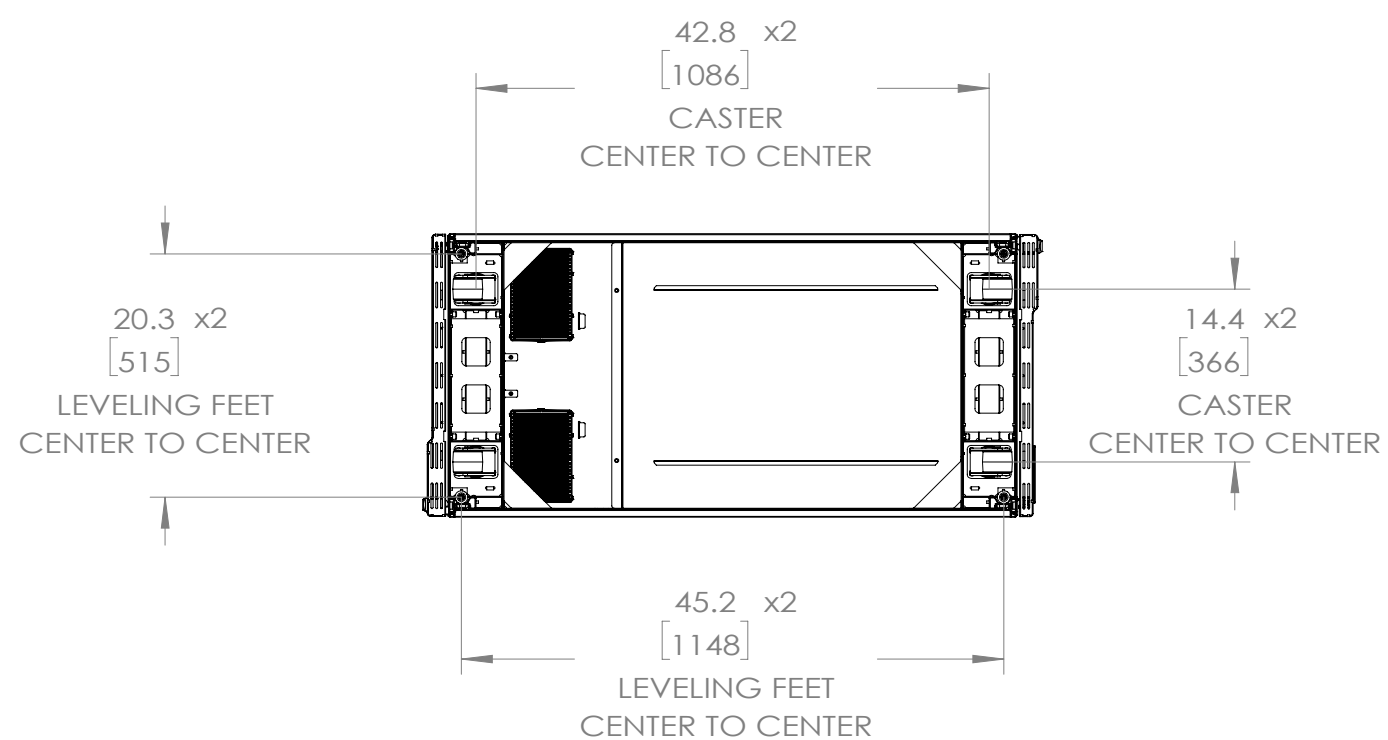
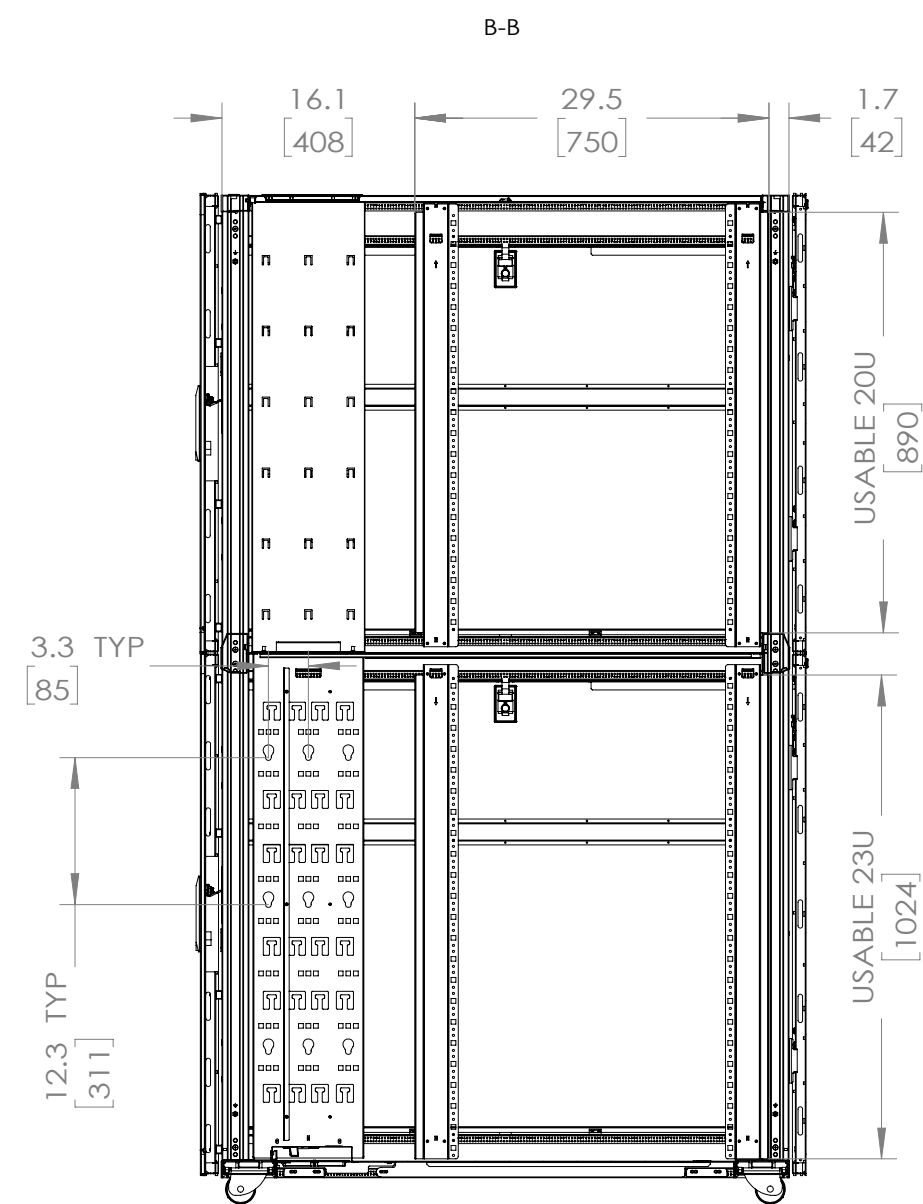
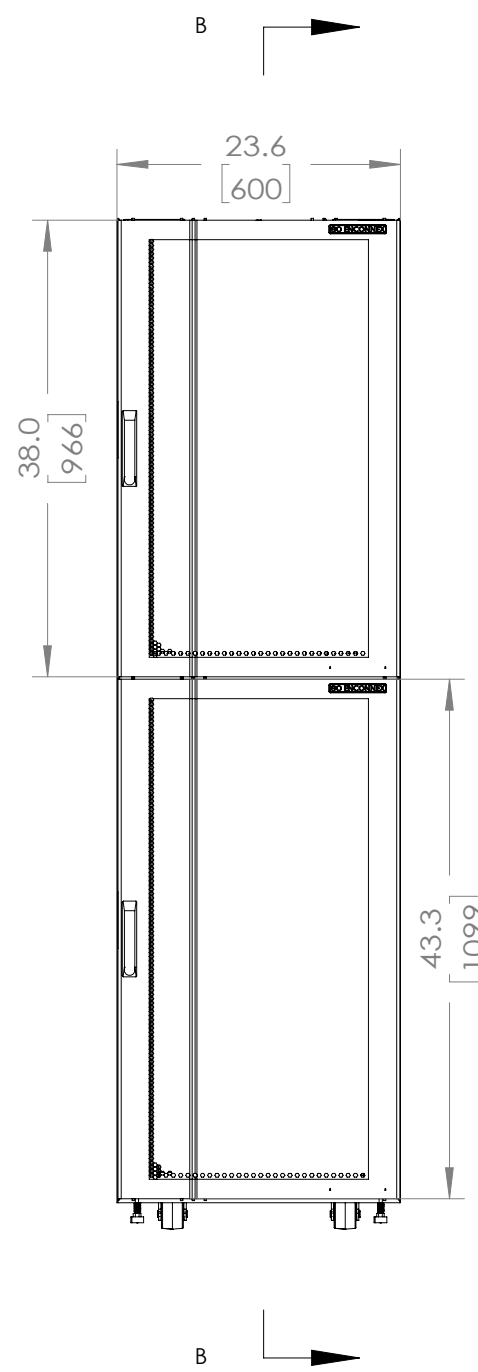
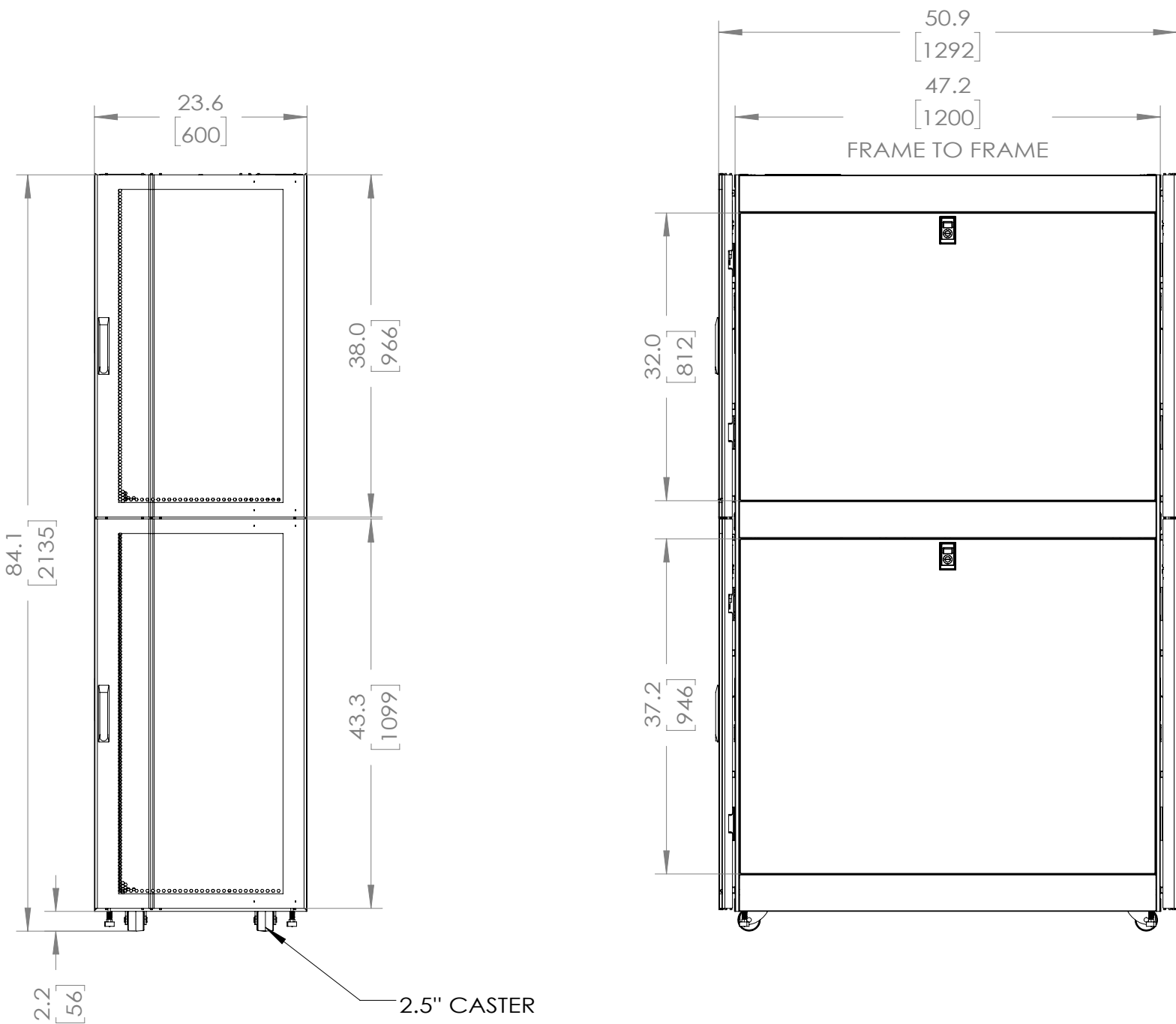
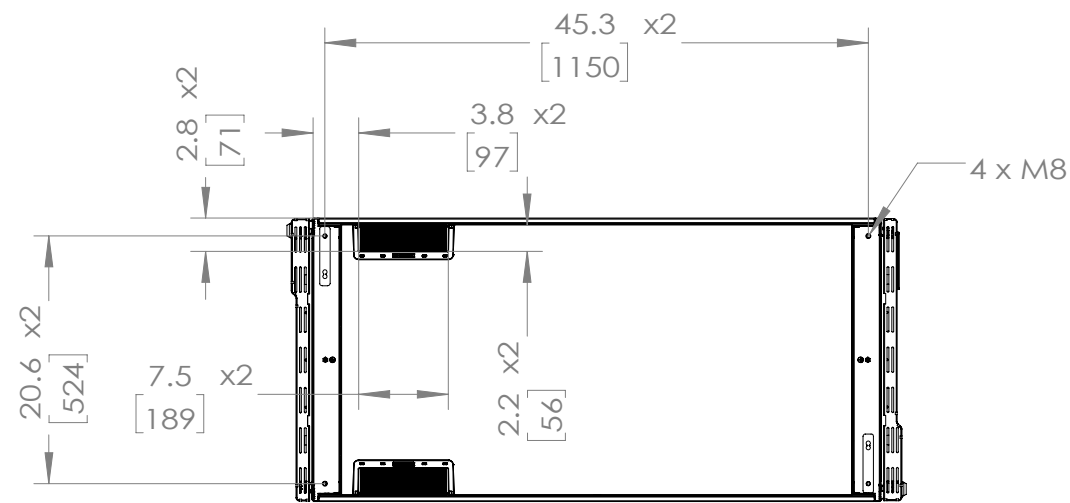

<p>PROPRIETARY AND CONFIDENTIAL</p> <p>This drawing and its specifications are the property of ENCONNEX and shall not be copied, reproduced, or used in whole or in part, as the basis for the manufacture or sale of items without written permission from ENCONNEX. This drawing is based upon the latest available information and is subject to change without notice.</p>		<p>UNLESS OTHERWISE SPECIFIED</p> <p>X = ± 1 XX = ± 0.5 XXX = ± 0.30 XXXX = ± 0.130 ANGULAR X = 1° .X = 0.5° .XX = 0.25°</p>		<p>4670 AIRCENTER CIRCLE RENO, NV 89502</p>		<p>DESCRIPTION:</p> <p>INFINIRACK MULTI-BAY, 600X1200, 20UX23U</p>	
<p>COMMENTS:</p>		<p>MATERIAL: SEE INDIVIDUAL</p>		<p>FINISH: N/A</p>		<p>CLASS: N/A</p>	
<p>DRAWN BY: YIFEI MAR 8, 2024</p>		<p>APP. BY: DUKE MAR 8, 2024</p>		<p>SCALE: 1:16</p>		<p>WEIGHT:</p>	
<p>UNITS: in [mm]</p>		<p>INTERPRET TO ASME Y14.100</p>		<p>DEBURR AND BREAK SHARP EDGES/CONTOURS AT 0.2mm MAX</p>		<p>DRAWING NO: E011200-01X</p>	
<p>REVISION: A</p>		<p>REVISION: A</p>		<p>REVISION: A</p>		<p>SHEET: 2 OF 3</p>	

11 10 9 8 7 6 5 4 3 2 1

NOTES:

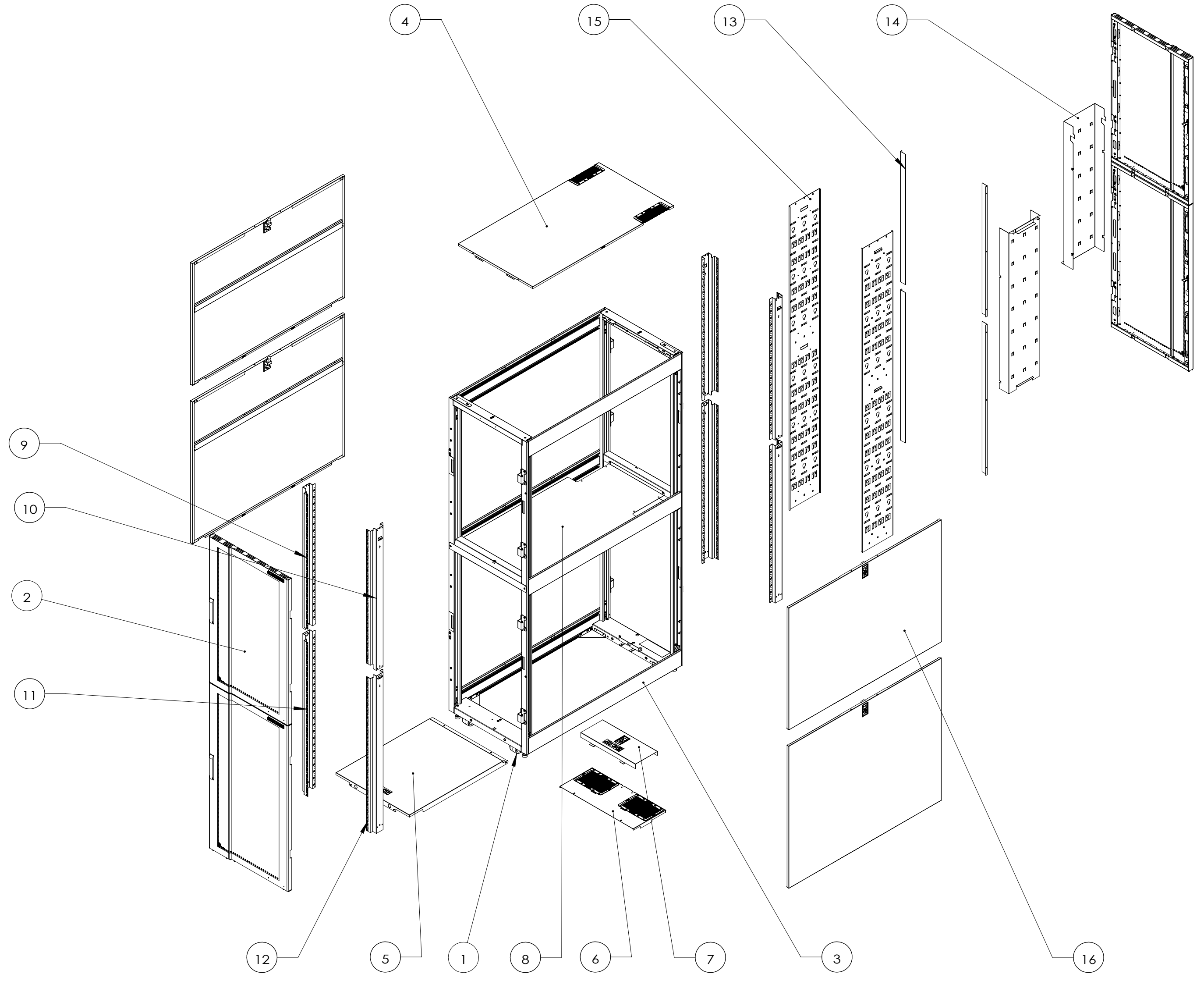

ITEM	PN	DESCRIPTION
1	441-0101-01X0	ASSY. SUB. MECH. INFINIRACK CUSTOM COMPARTMENT CABINET FRAME, 600mm, 45U, WITH CASTORS AND LEVELING FEET, BLACK/WHITE
2	441-0135-0XX0	ASSY. SUB. MECH. INFINIRACK FRONT DOOR, CURVE PERFORATED HALF HEIGHT DOOR, 600W, 21U/24U, W/GROUND WIRES, HINGES, W/O LOGO BADGE, BLACK/WHITE
3	426-0181-00X0	MANUFAC. PROCESS. COAT. INFINIRACK, COMPARTMENT HORIZONTAL BEAM, 1200mm DEPTH, BLACK/WHITE
4	441-0152-00X0	ASSY. SUB. MECH. INFINIRACK CUSTOM COMPARTMENT CABINET ROOF, 600mm, 1200mm, WITH BRUSH AND SPRING CLIP, BLACK/WHITE
5	426-0211-00X0	MANUFAC. PROCESS. COAT. INFINIRACK CUSTOM COMPARTMENT, FRONT HALF BOTTOM, 1200mm, BLACK/WHITE
6	426-0212-00X0	MANUFAC. PROCESS. COAT. INFINIRACK CUSTOM COMPARTMENT, REAR HALF BOTTOM, 1200mm, BLACK/WHITE
7	426-0213-00X0	ASSY. SUB. MECH. INFINIRACK CUSTOM COMPARTMENT, REAR HALF BOTTOM COVER, 1200mm, BLACK/WHITE
8	426-0260-00X0	MANUFAC. PROCESS. COAT. INFINIRACK CUSTOM COMPARTMENT, COMPARTMENT PARTITION PANEL, 600mm, 1200mm DEPTH, BLACK/WHITE
9	426-0122-01X0	MANUFAC. PROCESS. COAT. INFINIRACK CUSTOM COMPARTMENT, UPPER L RAIL, 600mm, 20U, BLACK/WHITE
10	426-0123-01X0	MANUFAC. PROCESS. COAT. INFINIRACK CUSTOM COMPARTMENT, UPPER R RAIL, 600mm, 20U, BLACK/WHITE
11	426-0124-02X0	MANUFAC. PROCESS. COAT. INFINIRACK CUSTOM COMPARTMENT, LOWER L RAIL, 600mm, 23U, BLACK/WHITE
12	426-0125-02X0	MANUFAC. PROCESS. COAT. INFINIRACK CUSTOM COMPARTMENT, LOWER R RAIL, 600mm, 23U, BLACK/WHITE
13	426-0126-0XX0	MANUFAC. PROCESS. COAT. INFINIRACK CUSTOM COMPARTMENT, LASHING PANEL PARTITION BRACKET, 21U/24U, BLACK/WHITE
14	426-0240-0XX0	MANUFAC. PROCESS. COAT. INFINIRACK CUSTOM COMPARTMENT, UPPER LASHING PANEL COVER, 21U/24U, W/ MOUNTING SCREWS, BLACK/WHITE
15	426-0236-01X0	MANUFAC. PROCESS. COAT. INFINIRACK CUSTOM COMPARTMENT, LASHING PANEL, 45U, W/ MOUNTING SCREWS, BLACK/WHITE
16	801-0109-01X0	FINAL ASSY. KIT, PANELS, COMPARTMENT CABINET SIDE PANELS, 45U, 1200mm DEPTH, 2 PCS, BLACK/WHITE

PROPRIETARY AND CONFIDENTIAL		UNLESS OTHERWISE SPECIFIED		 4670 AIRCENTER CIRCLE RENO, NV 89502		DESCRIPTION: INFINIRACK MULTI-BAY, 600X1200, 20UX23U	
This drawing and its specifications are the property of ENCONNEX and shall not be copied, reproduced, or used in whole or in part, as the basis for the manufacture or sale of items without written permission from ENCONNEX. This drawing is based upon the latest available information and is subject to change without notice.		X = ± 1 X.X = ± 0.5 X.XXX = ± 0.130 ANGULAR X = 1° X = 0.5° .XX = 0.25°					
COMMENTS:		MATERIAL: SEE INDIVIDUAL		FINISH: N/A		CLASS: N/A	
DRAWN BY: YIFEI	DATE: MAR 8, 2024	APP. BY: DUKE	DATE: MAR 8, 2024	DEBURR AND BREAK SHARP EDGES/CONTOURS AT 0.2mm MAX	SCALE: 1:18	WEIGHT:	SHEET: 3 OF 3
UNITS: in [mm]				INTERPRET TO ASME Y14.100		DRAWING NO: E011200-01X	
						REV NO: A	

11 10 9 8 7 6 5 4 3 2 1