

10

9

8

7

6

5

4

3

2

1

Notes/Instructions:

REV	REV DATE	DESCRIPTION	APPROVAL
A	2019-03-08	RELEASE	SDRF

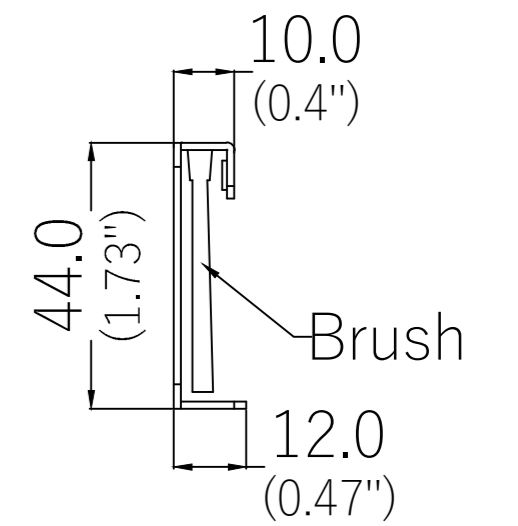
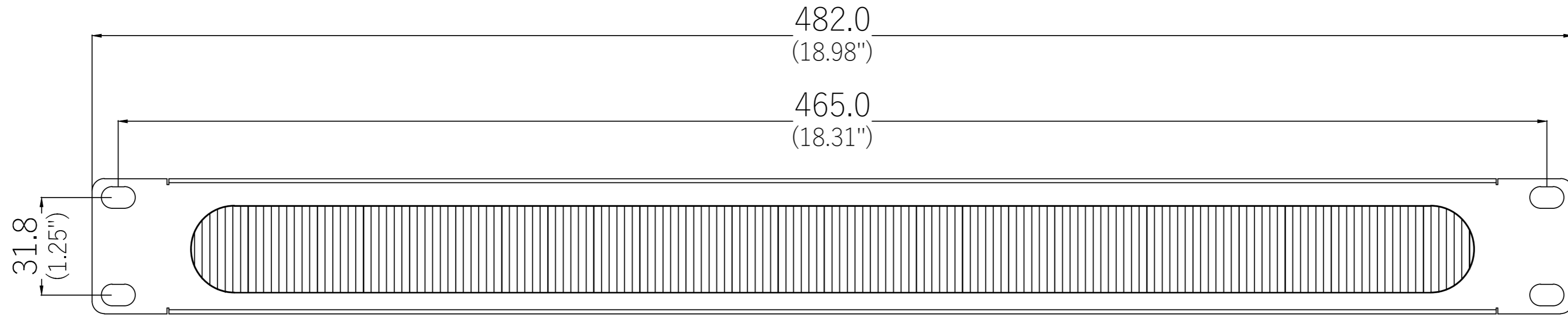
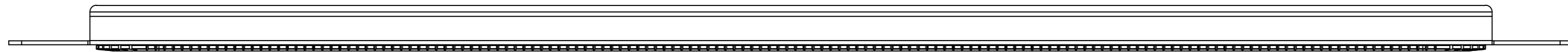

Notes:

This drawing and its specifications are the property of ENCONNEX and shall not be copied, reproduced, or used in whole or in part, as the basis for the manufacture or sale of items without written permission from ENCONNEX. This drawing is based upon the latest available information and is subject to change without notice.

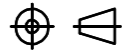
TOLERANCES LINEAR (mm) X = ± 1 XX = ± 0.5 XXX = ± 0.30 XXXX = ± 0.150 ANGULAR X = 1° .X = 0.5° .XX = 0.25°	MATERIAL: Metal	 4670 AIRCENTER CIRCLE, RENO, NV 89502	PART NUMBER: ECX-BRUSHPAL-1U
	FINISH:		DESCRIPTION: Enconnex 1U Brush Panel
 DEBUR AND BREAK SHARP EDGES/CORNERS AT 0.2mm MAX UNITS: mm [in]	INTERPRET TO ASME Y14.100 SIZE: A2 SCALE: 1:1	DRAWN BY: SAM DING APPROVED BY: R. FAULKNER	ORG DATE: 2019-03-08 REV DATE: 2019-03-08 SHEET: 2/2 REV: A

10

9

8

7

6

5

4

3

2

1