

THIS DRAWING AND SPECIFICATIONS HEREIN ARE THE PROPERTY OF ENCONNEX LLC. AND SHALL NOT BE COPIED, REPRODUCED OR USED IN WHOLE OR IN PART, AS THE BASIS FOR THE MANUFACTURE OR SALE OF ITEMS WITHOUT THE WRITTEN PERMISSION OF ENCONNEX LLC. THIS DRAWING IS SUBJECT TO CHANGE WITHOUT NOTICE.

REVISIONS				
REV.	SUFFIX	DESCRIPTION	DATE	APPROVED
A		Full Released	2019.3.8	FANCY FAN
B		Add the logo and confirm that can fit square holes on PMA	2022.4.26	FANCY FAN

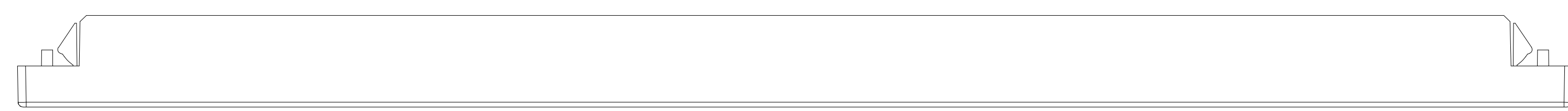

TOP VIEW

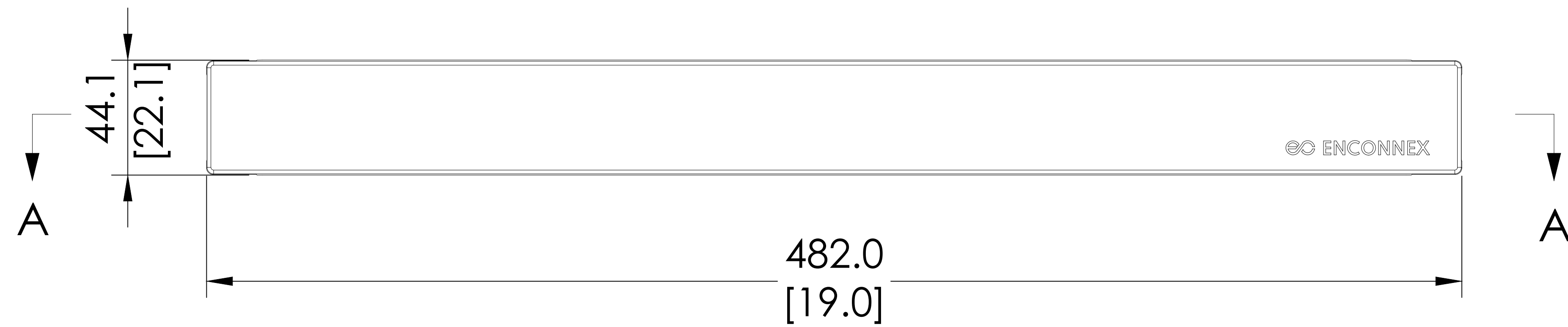

FRONT VIEW

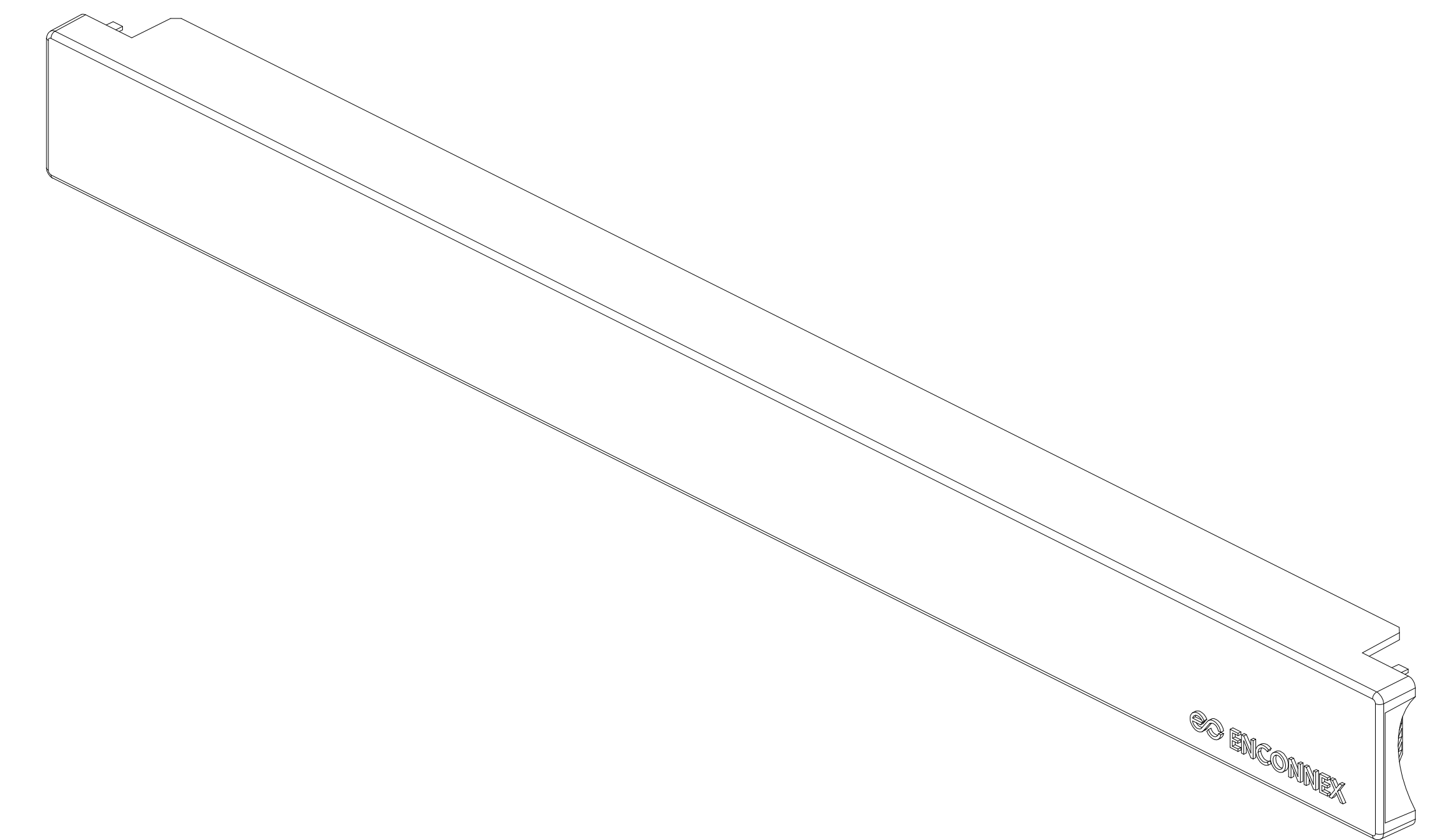
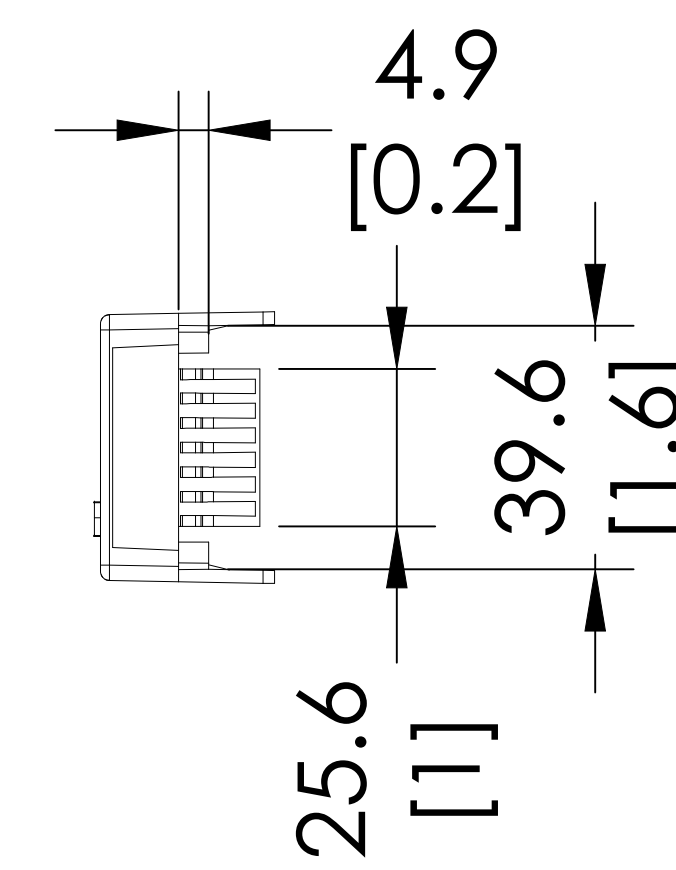

BOTTOM VIEW

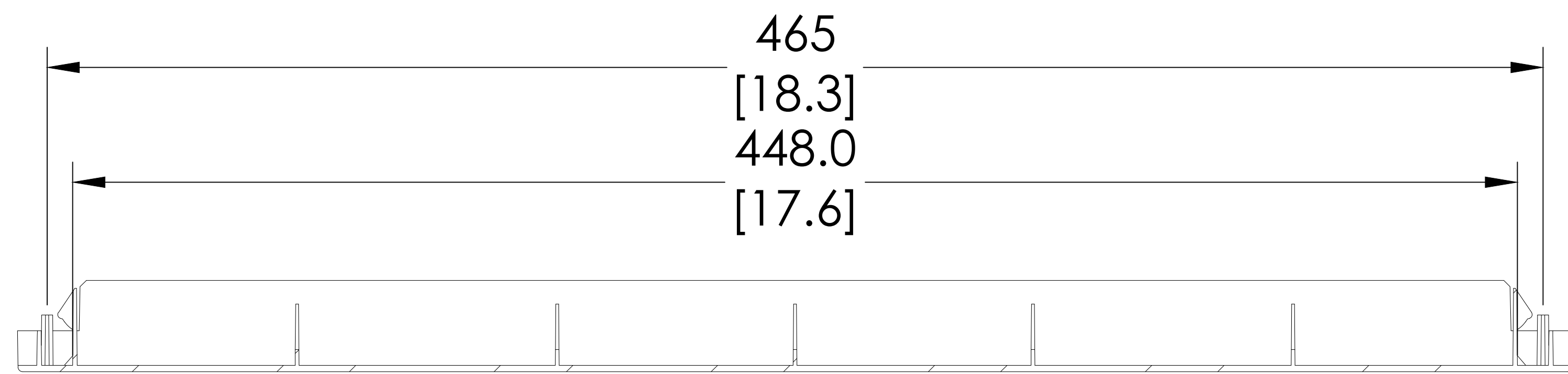

SECTIONAL VIEW
A-A

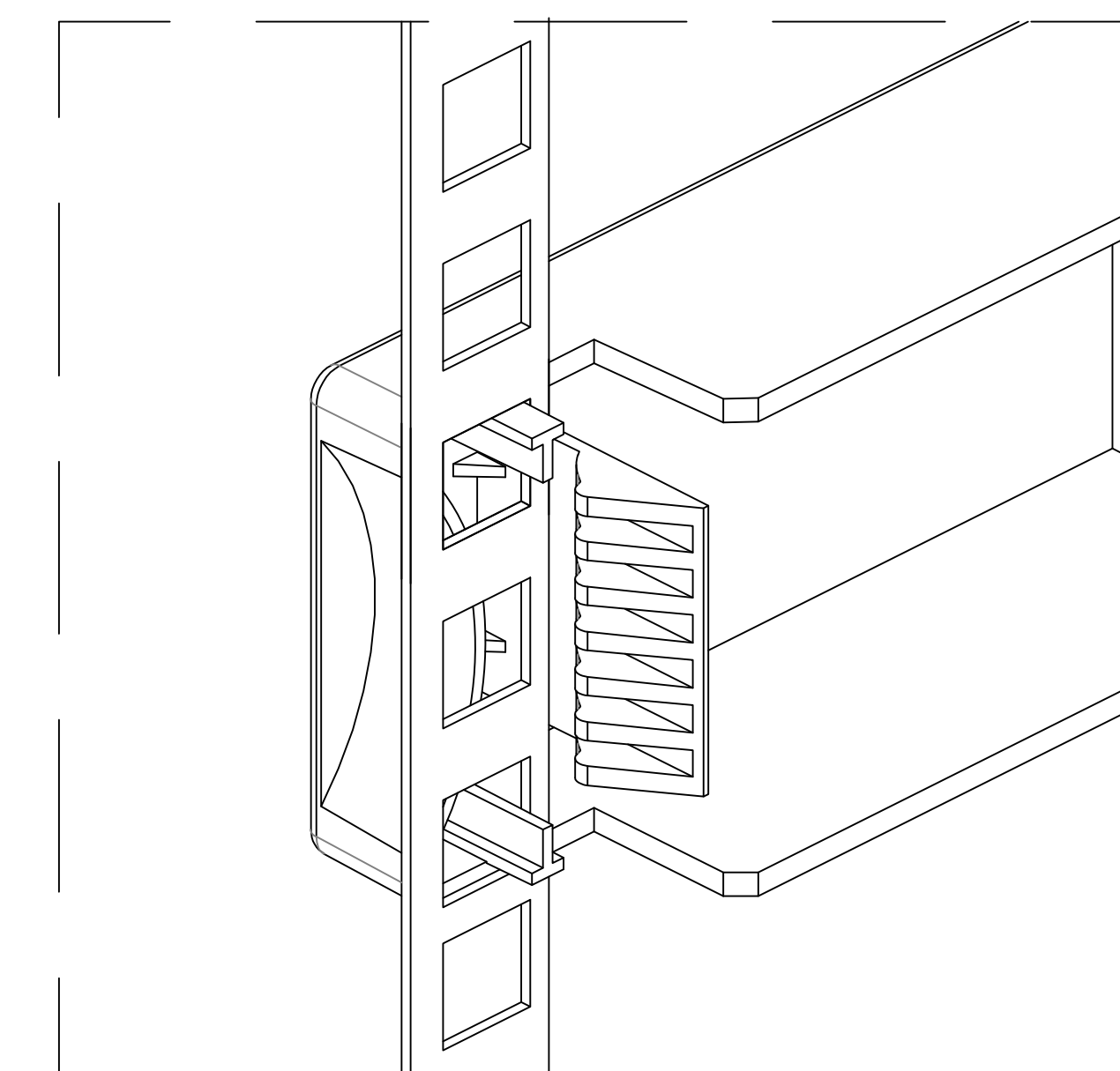

NOTES, UNLESS OTHERWISE SPECIFIED:

- MATERIAL: ABS
- FINISH: RAL 9005
- PART MUST BE SUFFICIENTLY FREE OF BURRS AND SHARP EDGES TO PASS UL 1439 SHARP EDGE TEST.
- 3D CAD AVAILABLE IN ADDITION TO PDF PRINT. SHOULD DISCREPANCY ARISE, CONSULT ENCONNEX ENGINEERING IMMEDIATELY.
- ALL PARTS TO BE FREE OF DIRT OR GRIME THAT PREVENTS LABEL ADHESION OR ALLOWS TRANSFER ONTO COSMETIC AREAS.
- MUST BE ROHS COMPLIANT, INCLUDING HARDWARE. IF CONFLICTING SPECIFICATIONS EXIST, CONTACT ENCONNEX ENGINEERING.
- DIMENSIONS IDENTIFIED WITH (X.XX) ARE CONSIDERED CRITICAL TO QUALITY (CTQ) DIMENSIONS. THESE DIMENSIONS ARE EXPECTED TO BE MONITORED STATISTICALLY AND DOCUMENTED AS PART OF THE FABRICATION PROCESS.

UNLESS NOTED, DIMENSIONS IN MILLIMETERS & TOLERANCES ARE:

X.	±1	MM	X°	±1°
X.X	±0.5	MM	X.X°	±0.5°
X.XX	±0.20	MM		
ØX.X	±0.3	MM		
ØX.XX	±0.10	MM		



PRODUCT LINE:
Cabinet Accessory

PART NUMBER:
ECX-1UBLANPAN

DESCRIPTION:
1u Toolless Snap in Blanking Panel

THIRD ANGLE PROJECTION	DRAWING FILE NAME ECX-1UBLANPAN	ENGINEER: AMY ZHU	ORG DATE: 2019.3.8
	3D MODEL FILE NAME ECX-1UBLANPAN	DRAWN: AMY ZHU	REV DATE: 2022.4.26
	3D MODEL CONFIGURATION Default	ITEM WEIGHT (REFERENCE ONLY)	
UNITS:MM[IN]	INTERPRET TO ASME Y14.100	SIZE: B	SCALE:1:5
		DO NOT SCALE DRAWING	SHEET:B

REV:1/2

8 7 6 5 4 3 2 1

F

F

E

E

D

D

C

C

B

B

A

A

8 7 6 5 4 3 2 1

THIS DRAWING AND SPECIFICATIONS HEREIN ARE THE PROPERTY OF ENCONNEX LLC. AND SHALL NOT BE COPIED, REPRODUCED OR USED IN WHOLE OR IN PART, AS THE BASIS FOR THE MANUFACTURE OR SALE OF ITEMS WITHOUT THE WRITTEN PERMISSION OF ENCONNEX LLC. THIS DRAWING IS SUBJECT TO CHANGE WITHOUT NOTICE.

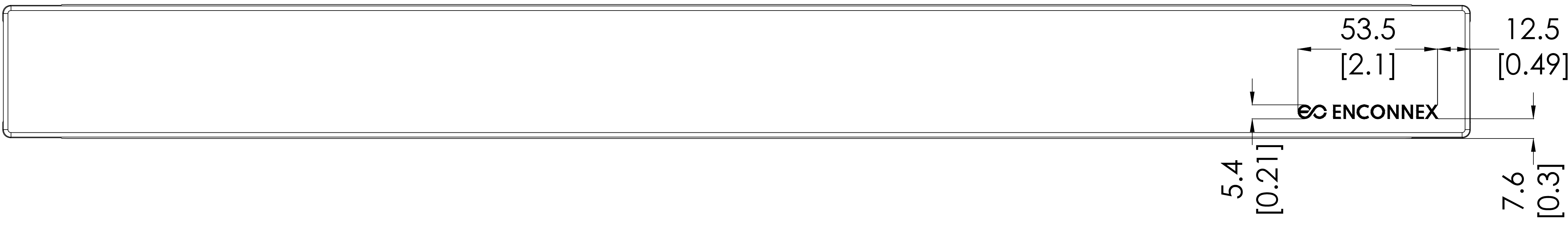

SILKSCREEN
COLOR-[R:255 G:255 B:255]

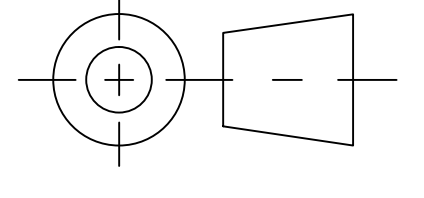
UNLESS NOTED, DIMENSIONS IN MILLIMETERS & TOLERANCES ARE:		 ENCONNEX	PRODUCT LINE: Cabinet Accessory	
X. ±1 MM	X° ±1°		PART NUMBER: ECX-1UBLANPAN	
X.X ±0.5 MM	X.X° ±0.5°	4670 AIRCENTER CIRCLE, RENO, NV89502	DESCRIPTION: 1u Toolless Snap in Blanking Panel	
X.XX ±0.20 MM			DRAWING FILE NAME ECX-1UBLANPAN	
ØX.X ±0.3 MM		3D MODEL FILE NAME ECX-1UBLANPAN		ENGINEER: AMY ZHU
ØX.XX ±0.10 MM		3D MODEL CONFIGURATION Default		ORG DATE: 2019.3.8
 THIRD ANGLE PROJECTION	UNITS:MM[IN]		ITEM WEIGHT (REFERENCE ONLY)	REV DATE: 2022.4.26
	INTERPRET TO ASME Y14.100		SCALE:1:5	REV:2/2
SIZE: B		DO NOT SCALE DRAWING		SHEET:B

8 7 6 5 4 3 2 1