

Product Specification

500m 100G QSFP28 DR1 Optical Transceiver Module

ECX-QSFP28-DR1-GN-03

PRODUCT FEATURES

- QSFP28 MSA compliant
- Compliant to 802.3cu
- 100G DR1 Specification compliant
- Maximum power consumption 4.5W
- LC connector
- Up to 500m transmission on single mode fiber with FEC
- Operating case temperature: 0°C~70°C
- Single 3.3V power supply
- RoHS-6 compliant

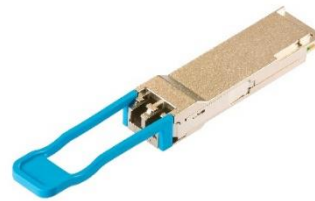

APPLICATIONS

- 100G Ethernet
- Data Center Interconnect
- Enterprise networking

DESCRIPTION

It is a transceiver module designed for 500m optical communication applications, and it is compliant to IEEE 802.3cu 100G DR1 MSA standard. This module can convert 4-channel 26.5625Gb/s electrical data to 1-channel 106.25Gb/s optical signals. Similarly, it can convert 1-channel 106.25Gb/s optical signals to 4-channel out-

put electrical data on the receiver side. It has been designed to meet the harshest external operating conditions including temperature, humidity and EMI interference. The module offers very high functionality and feature integration, accessible via a two-wire serial interface.

Transceiver Block Diagram

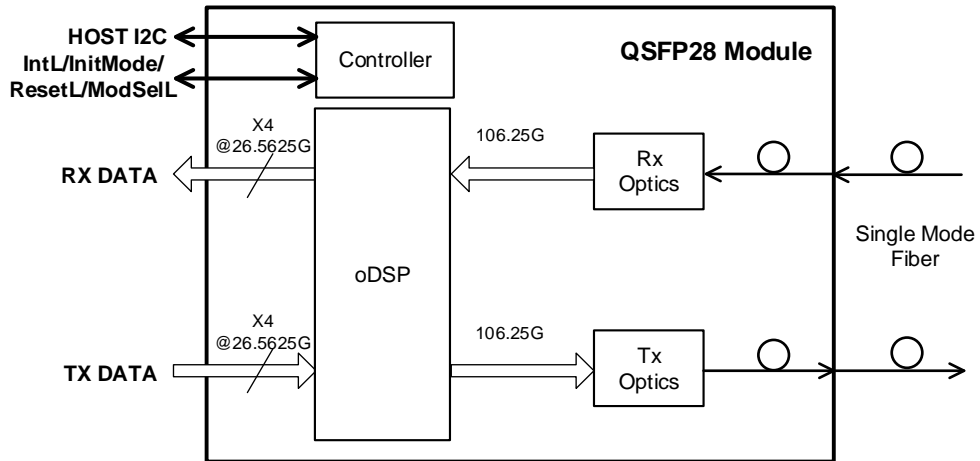

Figure 1. Transceiver Block Diagram

Proposed Application Schematics

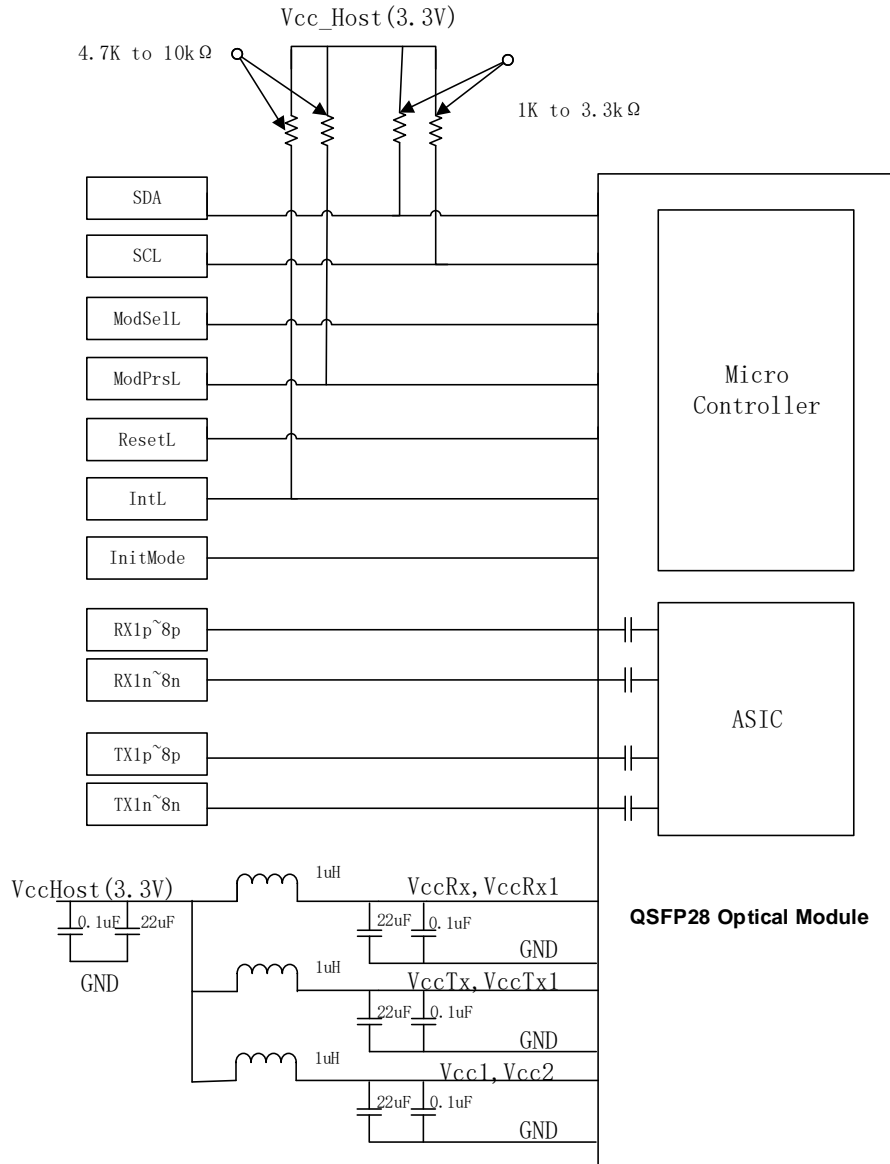

Figure 2. Proposed Application Schematics

Pin Descriptions

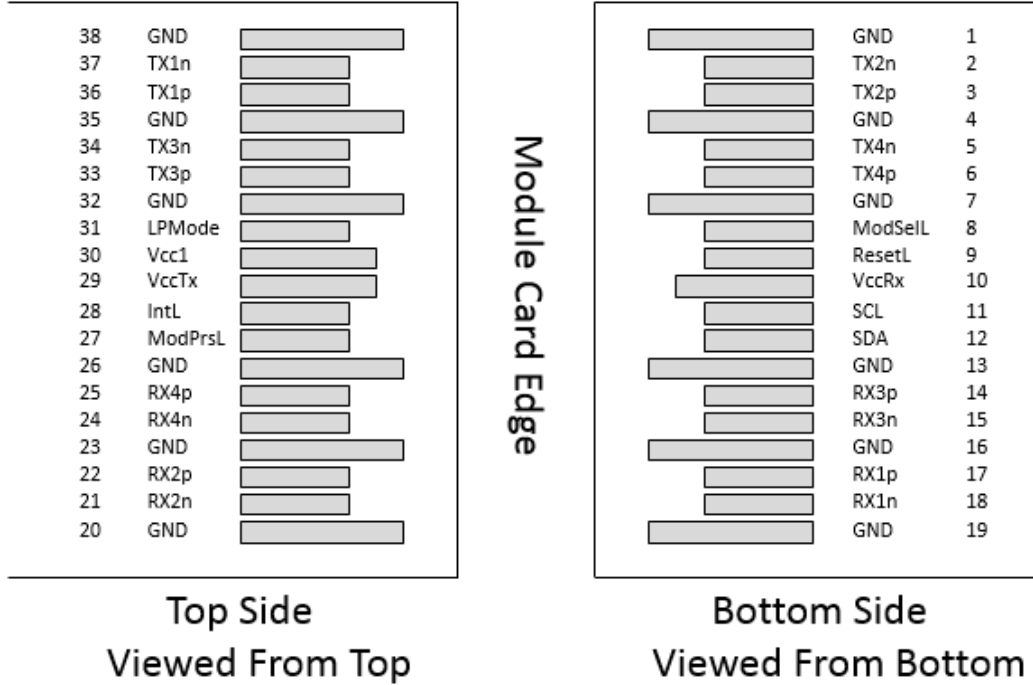

Figure 3. QSFP28 MSA compliant Connector

Pin	Symbol	Description	Notes
1	GND	Ground	1
2	Tx2n	Transmitter Inverted Data Input	
3	Tx2p	Transmitter Non-Inverted Data Input	
4	GND	Ground	1
5	Tx4n	Transmitter Inverted Data Input	
6	Tx4p	Transmitter Non-Inverted Data Input	
7	GND	Ground	1
8	ModSelL	Module Select	
9	ResetL	Module Reset	
10	Vcc Rx	+3.3V Power Supply Receiver	
11	SCL	2-wire serial interface clock	
12	SDA	2-wire serial interface data	
13	GND	Ground	1
14	Rx3p	Receiver Non-Inverted Data Output	
15	Rx3n	Receiver Inverted Data Output	
16	GND	Ground	1
17	Rx1p	Receiver Non-Inverted Data Output	
18	Rx1n	Receiver Inverted Data Output	
19	GND	Ground	1

Pin	Symbol	Description	Notes
20	GND	Ground	1
21	Rx2n	Receiver Inverted Data Output	
22	Rx2p	Receiver Non-Inverted Data Output	
23	GND	Ground	1
24	Rx4n	Receiver Non-Inverted Data Output	
25	Rx4p	Receiver Inverted Data Output	
26	GND	Ground	1
27	ModPrsL	Module Present	
28	IntL	Interrupt	
29	Vcc Tx	+3.3V Power supply transmitter	
30	Vcc1	+3.3V Power supply	
31	LPMODE	Low Power Mode	
32	GND	Ground	1
33	Tx3p	Transmitter Non-Inverted Data Input	
34	Tx3n	Transmitter Inverted Data Input	
35	GND	Ground	1
36	Tx1p	Transmitter Non-Inverted Data Input	
37	Tx1n	Transmitter Inverted Data Input	
38	GND	Ground	1

Absolute Maximum Ratings

It has to be noted that the operation in excess of any individual absolute maximum ratings might cause permanent damage to this module.

Parameter	Sym- bol	Min	Typ	Max	Unit	Notes
Maximum Supply Voltage	Vcc	-0.5	3.3	3.6	V	
Storage Temperature	Ts	-40		85	°C	
Relative Humidity	RH	0		85	%	1
Damage Threshold, each lane	THd	5.5			dBm	
Notes:						
1. Non-condensing						

Operating Environments

Electrical and optical characteristics below are defined under this operating environment, unless otherwise specified.

Parameter	Symbol	Min	Typ	Max	Unit
Supply Voltage	Vcc	3.135	3.3	3.465	V
Case Temperature	T	0		70	°C
Data Rate Accuracy		-100		100	ppm
Link Distance with G.652		2		500/2000	m

Electrical Characteristics

Parameter	Symbol	Min	Typ	Max	Unit	Note
Power dissipation	P			4.5	W	
Supply Current	Icc			1.435	A	
Transmitter						
Data Rate, each lane		26.5625 ±100ppm			GBd	
Differential input Voltage pk-pk	Vpp	900			mV	1
Common Mode Voltage	Vcm	-350		2850	mV	2
Differential Termination Resistance Mismatch				10	%	
Single-ended Voltage Tolerance Range (Min)		-0.4		3.3	V	
Differential Input Return Loss		IEEE 802.3-2015 Equation (83E-5)			dB	
Differential to Common Mode Input Return Loss		IEEE 802.3-2015 Equation (83E-6)			dB	
Module Stressed Input		IEEE 802.3cu				3

Test						
Receiver						
Data Rate, each lane		26.5625 ±100ppm			GBd	
Differential Termination Resistance Mismatch				10	%	
Differential output Voltage pk-pk	V _{pp}			900	mV	
Common Mode Voltage	V _{cm}	-350		2850	mV	2
Common Mode Noise, RMS	V _{rms}			17.5	mV	
Transition time (min)		9.5			ps	20%to80%
Near-end Eye height, differential (min)		70			mV	
Near-end ESMW (Eye symmetry mask width)		0.265			UI	
Far-end ESMW (Eye symmetry mask width)		0.2			UI	
Far-end Eye height, differential (min)		30			mV	
Far-end pre-cursor ISI ratio		-4.5		2.5	dB	
Differential output return loss		IEEE 802.3-2015 Equation (83E-2)				
Common to differential mode conversion return loss		IEEE 802.3-2015 Equation (83E-3)				
Note:						
1. With the exception to IEEE 802.3cu that the pattern is PRBS31Q or scrambled idle.						

2. DC common mode voltage generated by the host. Specification includes effects of ground offset voltage.

3. BER specified in IEEE 802.3 cu.

Optical Characteristics

Parameters	Unit	min	type	max
Transmitter				
Data Rate	GBd	53.125±100ppm		
Modulation Format		PAM4		
Line wavelengths	nm	1304.5	1311	1317.5
Average Launch Power	dBm	-2.4		4
Optical Modulation Amplitude (OMA)	dBm	-0.2		4.2
Extinction Ratio (ER)	dB	3.5		
Side-Mode Suppression Ratio (SMSR)	dB	30		
Launch power in OMA minus TDECQ	dB	-1.6(ER≥4.5dB) -1.5(ER<4.5dB)		
Transmitter and Dispersion Eye Clouser for PAM4 (TDECQ)	dB			3.4
RIN _{15.5OMA}	dB/Hz			-136
Optical Return Loss Tolerance	dB			15.5
Transmitter Reflectance	dB			-26
Average Launch Power of OFF Transmitter	dBm			-15
Receiver				
Data Rate	GBd	53.125±100ppm		
Modulation Format		PAM4		
Damage Threshold	dBm	5.5		
Line wavelengths	nm	1304.5		1317.5

Average receiver power	dBm	-6.4		4.5
Receiver power (OMA)	dBm			4.7
Receiver Sensitivity (OMAouter) (max)	dBm			Max(-4.5,SECQ-5.9)
Stressed receiver Sensitivity (OMAouter) (max)	dBm			-2.5
LOS Assert	dBm	-13		
LOS Deassert	dBm			-8
LOS Hysteresis	dB	0.5		
Receiver reflectance	dB			-26
Conditions of Stressed Receiver Sensitivity				
Stressed eye closure for PAM4 (SECQ), lane under test	dB			3.4
Note:				
1. Receiver sensitivity (OMAouter), each lane (max) is informative and is defined for a transmitter with SECQ of 0.9 dB				
2. Measured with conformance test signal for BER = 2.4x10 ⁻⁴ . A compliant receiver shall have stressed receiver sensitivity (OMA outer), each lane values below the mask of Figure 3, for SECQ values between smaller than 3.4 dB.				

EEPROM Definitions

Lower Memory Map

data address	Name	Description	Value (hex)	Read /Write
0	ID & version ID	Identifier	0X18	RO
1		Revision Compliance	0X30	RO
2		flate_men/CLEI/TWI max speed	*	RO
3		Module state/interrupt	*	RO
4	Bank lane Flag Summary	Bank 0 lane1~8 flag summary	*	RO
5		Bank 1 lane1~8 flag summary	*	RO
6		Bank 2 lane1~8 flag summary	*	RO
7		Bank 3 lane1~8 flag summary	*	RO
8	Module Flags	firmware fault & L-Module state change flage	*	RO
9		3.3V&temperture low/high alarm/warning flag	*	RO

10		L-Aux1 &L-Aux2 low/high alarm/warning flag	*	RO
11		L-Vendor define & L-Aux3 low/high alarm/warning flag	*	RO
12		reserved	00	RO
13		custom	00	RO
14	Module Monitors	temperature1 MSB	*	RO
15		temperature1 LSB	*	RO
16		Supply 3.3 MSB	*	RO
17		Supply 3.3 LSB	*	RO
18		AUX 1 MSB	*	RO
19		AUX 1 LSB	*	RO
20		AUX 2 MSB	*	RO
21		AUX 2 LSB	*	RO
22		AUX 3 MSB	*	RO
23		AUX 3 LSB	*	RO
24		Custom MSB	*	RO
25		Custom LSB	*	RO
26	Module Global Controls	Squelch control / Force-LowPwr/soft reset	00	RW
27		reserved	00	RW
28				RW
29		Custom	00	RW
30				RW
31	Module masks	Mask bit for Module State Changed Flag	00	RW
32		Mask bit for temp&supply 3.3V low/high alarm/warning flag	00	RW
33		Mask bit for AUX1&AUX2 low/high alarm/warning flag	00	RW
34		Mask bit for AUX3&Vendor define low/high alarm/warning flag	00	RW
35		reserved	00	RW
36		Custom	00	RW
37	Reserved			
38				
39				
40			00	RO
41				
42				
43				

44			
45			
46			
47			
48			
49			
50			
51			
52			
53			
54			
55			
56			
57			
58			
59			
60			
61			
62			
63			
64			
65			
66			
67			
68			
69			
70			
71			
72			
73			
74	Custom		00 RW
75			
76			
77			
78			
79			
80			
81			
82			
83			
84			

85	Module Type Advertising code	Module Type Code	02	RO
86	Module Host-media interface Advertising options	Host Electrical Interface Code	11	RO
87		Module Media Interface Code	1D	RO
88		Host/Media LANE Count	84	RO
89		Host lane Assignment Options	01	RO
90		Host Electrical Interface Code	FF	RO
91		Module Media Interface Code	00	RO
92		Host/Media LANE Count	00	RO
93		Host lane Assignment Options	00	RO
94		Host Electrical Interface Code	00	RO
95		Module Media Interface Code	00	RO
96		Host/Media LANE Count	00	RO
97		Host lane Assignment Options	00	RO
98		Host Electrical Interface Code	00	RO
99		Module Media Interface Code	00	RO
100		Host/Media LANE Count	00	RO
101		Host lane Assignment Options	00	RO
102		Host Electrical Interface Code	00	RO
103		Module Media Interface Code	00	RO
104		Host/Media LANE Count	00	RO
105		Host lane Assignment Options	00	RO
106		Host Electrical Interface Code	00	RO
107		Module Media Interface Code	00	RO
108		Host/Media LANE Count	00	RO
109		Host lane Assignment Options	00	RO
110		Host Electrical Interface Code	00	RO
111		Module Media Interface Code	00	RO
112		Host/Media LANE Count	00	RO
113		Host lane Assignment Options	00	RO
114		Host Electrical Interface Code	00	RO
115		Module Media Interface Code	00	RO
116		Host/Media LANE Count	00	RO
117		Host lane Assignment Options	00	RO
118		password Change Area		00
119	00			
120	00			
121	00			
122	Password Area		00	WO
123			00	
124			00	

125			00	
126	Bank Select Byte		00	RW
127	Page Select Byte		00	RW

Upper Memory Map Page 00h

data address	Name	Description	Value (hex)	Read/Write
128	Identifier	ID	18	RO
129	Vendor name	Vendor name	*	RO
130				
131				
132				
133				
134				
135				
136				
137				
138				
139				
140				
141				
142				
143				
144				
145	Vender OUI	Vendor Organizationally Unique ID	*	RO
146				
147				
148	Vender PN	Vender Part Number	*	RO
149				
150				
151				
152				
153				
154				
155				
156				
157				
158				
159				
160				
161				
162				

163				
164	Vender rev	Vender Revision Number	*	RO
165				
166	Vender SN	Vender Serial Number	*	RO
167				
168				
169				
170				
171				
172				
173				
174				
175				
176				
177				
178				
179				
180				
181				
182	Data Code	Data Code year	*	RO
183		Data Code month	*	RO
184		Data Code day of month	*	RO
185		Lot code	*	RO
186				
187	CLEI Code	Common Language Equipment ID	*	RO
188				
189				
190				
191				
192				
193				
194				
195				
196				
197				
198				
199				
200	Module power characteristics	Module Power Class	A0	RO
201		Module MAX Power	30	RO
202	cable assembly length	cable assembly length	00	RO
203	Media Connector Type	Connector Type	07	RO

204	Copper Cable Attenuation	5G attenuation	00	RO	
205		7G attenuation	00	RO	
206		12.9G attenuation	00	RO	
207		25.8G attenuation	00	RO	
208		Reserved		00	RO
209					
210	Cable Assembly Lane Information	near end implementation lane1~8	00	RO	
211		Far end Configuration	00	RO	
212	Media Interface Technology	wanlength&device	06	RO	
213	Reserved		00	RO	
214					
215					
216					
217					
218					
219					
220					
221	Custom		00	RO	
222	Checksum	Checksum for 128~221	*	RO	
223	Custom Info NV		00	RO	
224					
225					
226					
227					
228					
229					
230					
231					
232					
233					
234					
235					
236					
237					
238					
239					
240					
241					
242					
243					

244				
245				
246				
247				
248				
249				
250				
251				
252				
253				
254				
255				

Upper Memory Map Page 01h

data address	Name	Description	Value (hex)	Read/Write
128	Module FW&HW REV	Module firmware major revision	*	RO
129		Module firmware minor revision	*	RO
130		Module hardware major revision	*	RO
131		Module hardware minor revision	*	RO
132	Supported Link Length	Base Length (SMF)	14	RO
133		Length (OM5)	00	RO
134		Length (OM4)	00	RO
135		Length (OM3)	00	RO
136		Length (OM2)	00	RO
137		Reserved	00	RO
138	Nominal Wavelength	wavelength MSB	65	RO
139		wavelength LSB	90	RO
140	Wavelength Tolerance	Wavelength Tolerance MSB	17	RO
141		Wavelength Tolerance LSB	70	RO
142	Implemengted management interface futures advertising	Diagnostic/page03/banks implemented	04	RO
143		ModSel wait time	f0	RO
144		DataPathDeinit/DataPathInit MaxDuration	88	RO
145	Module Characteristics advertising	Synchronous/Aux	80	RO
146		Maximum module temperature	46	RO
147		Minimum module temperature	00	RO
148		Propagation Delay MSB	00	RO
149		Propagation Delay LSB	00	RO
150		Minimum operating voltage	9c	RO
151		Rx Type	08	RO

152		per lane CDR Power saved	64	RO
153		Rx Output Amplitude code/Max Txeq	00	RO
154		Max Rx Out Eq Post/Pre-cursor	00	RO
155	Implemented Controls advertising	Tx Squelch/Disable/Polarity	02	RO
156		Rx Squelch/Disable/Polarity	00	RO
157	Implemented Flags advertising	Tx Fault/Los/LoL Flag	01	RO
158		Rx Los/LoL Flag	02	RO
159	Implemented Monitors advertising	Monitor enable	0b	RO
160		Tx Bias current multiplier /Rx Power/Tx Power/Tx Bias enable	07	RO
161	Implemented Signal Integrity Controls advertising	TX EQ/CDR Control	00	RO
162		RX EQ/CDR Control	00	RO
163	Reserved		00	RO
164				
165				
166				
167				
168				
169				
170				
171				
172				
173				
174				
175				
176	Module Media Lane advertising	Media Lane Assignment Options, ApSel 0001b	01	RO
177		Media Lane Assignment Options, ApSel 0010b	00	RO
178		Media Lane Assignment Options, ApSel 0011b	00	RO
179		Media Lane Assignment Options, ApSel 0100b	00	RO
180		Media Lane Assignment Options, ApSel 0101b	00	RO
181		Media Lane Assignment Options, ApSel 0110b	00	RO
182		Media Lane Assignment Options, ApSel 0111b	00	RO
183		Media Lane Assignment Options,	00	RO

		ApSel 1000b		
184		Media Lane Assignment Options, ApSel 1001b	00	RO
185		Media Lane Assignment Options, ApSel 1010b	00	RO
186		Media Lane Assignment Options, ApSel 1011b	00	RO
187		Media Lane Assignment Options, ApSel 1100b	00	RO
188		Media Lane Assignment Options, ApSel 1101b	00	RO
189		Media Lane Assignment Options, ApSel 1110b	00	RO
190		Media Lane Assignment Options, ApSel 1111b	00	RO
191	Custom		00	RO
192				
193				
194				
195				
196				
197				
198				
199				
200				
201				
202				
203				
204				
205				
206				
207				
208				
209				
210				
211				
212				
213				
214				
215				
216				
217				

218				
219				
220				
221				
222				
223	Extend Module Host-Media Interface Advertising options	HOST Electrical Interface Code	00	RO
224		Module Media Interface Code	00	RO
225		HOST /Media Lane Count	00	RO
226		HOST Lane Assignment Options	00	RO
227		HOST Electrical Interface Code	00	RO
228		Module Media Interface Code	00	RO
229		HOST /Media Lane Count	00	RO
230		HOST Lane Assignment Options	00	RO
231		HOST Electrical Interface Code	00	RO
232		Module Media Interface Code	00	RO
233		HOST /Media Lane Count	00	RO
234		HOST Lane Assignment Options	00	RO
235		HOST Electrical Interface Code	00	RO
236		Module Media Interface Code	00	RO
237		HOST /Media Lane Count	00	RO
238		HOST Lane Assignment Options	00	RO
239		HOST Electrical Interface Code	00	RO
240		Module Media Interface Code	00	RO
241		HOST /Media Lane Count	00	RO
242		HOST Lane Assignment Options	00	RO
243		HOST Electrical Interface Code	00	RO
244		Module Media Interface Code	00	RO
245		HOST /Media Lane Count	00	RO
246	HOST Lane Assignment Options	00	RO	
247	HOST Electrical Interface Code	00	RO	
248	Module Media Interface Code	00	RO	
249	HOST /Media Lane Count	00	RO	
250	HOST Lane Assignment Options	00	RO	
251	Rerved			
252				
253			00	RO
254				
255	Checksum	130~254	*	RO

Upper Memory Map Page 02h

data address	Name	Description	Value (hex)	Read/Write
--------------	------	-------------	-------------	------------

128	Module-Level monitor thresholds	Temperature monitor high alarm threshold MSB	50	RO
129		Temperature monitor high alarm threshold LSB	00	RO
130		Temperature monitor low alarm threshold MSB	f6	RO
131		Temperature monitor low alarm threshold LSB	00	RO
132		Temperature monitor high warning threshold MSB	46	RO
133		Temperature monitor high warning threshold LSB	00	RO
134		Temperature monitor low warning threshold MSB	00	RO
135		Temperature monitor low warning threshold LSB	00	RO
136		Supply 3.3-volt monitor high alarm threshold MSB	8d	RO
137		Supply 3.3-volt monitor high alarm threshold LSB	cc	RO
138		Supply 3.3-volt monitor low alarm threshold MSB	74	RO
139		Supply 3.3-volt monitor low alarm threshold LSB	04	RO
140		Supply 3.3-volt monitor high warning threshold MSB	87	RO
141		Supply 3.3-volt monitor high warning threshold LSB	5a	RO
142		Supply 3.3-volt monitor low warning threshold MSB	7a	RO
143		Supply 3.3-volt monitor low warning threshold LSB	76	RO
144		Aux 1 monitor high alarm threshold MSB	*	RO
145		Aux 1 monitor high alarm threshold LSB	*	RO
146		Aux 1 monitor low alarm threshold MSB	*	RO
147		Aux 1 monitor low alarm threshold LSB	*	RO
148	Aux 1 monitor high warning threshold MSB	*	RO	

149	Aux 1 monitor high warning threshold LSB	*	RO
150	Aux 1 monitor low warning threshold MSB	*	RO
151	Aux 1 monitor low warning threshold LSB	*	RO
152	Aux 2 monitor high alarm threshold MSB	*	RO
153	Aux 2 monitor high alarm threshold LSB	*	RO
154	Aux 2 monitor low alarm threshold MSB	*	RO
155	Aux 2 monitor low alarm threshold LSB	*	RO
156	Aux 2 monitor high warning threshold MSB	*	RO
157	Aux 2 monitor high warning threshold LSB	*	RO
158	Aux 2 monitor low warning threshold MSB	*	RO
159	Aux 2 monitor low warning threshold LSB	*	RO
160	Aux 3 monitor high alarm threshold MSB	*	RO
161	Aux 3 monitor high alarm threshold LSB	*	RO
162	Aux 3 monitor low alarm threshold MSB	*	RO
163	Aux 3 monitor low alarm threshold LSB	*	RO
164	Aux 3 monitor high warning threshold MSB	*	RO
165	Aux 3 monitor high warning threshold LSB	*	RO
166	Aux 3 monitor low warning threshold MSB	*	RO
167	Aux 3 monitor low warning threshold LSB	*	RO
168	Custom monitor high alarm threshold MSB	*	RO
169	Custom monitor high alarm threshold LSB	*	RO

170		Custom monitor low alarm threshold MSB	*	RO
171		Custom monitor low alarm threshold LSB	*	RO
172		Custom monitor high warning threshold MSB	*	RO
173		Custom monitor high warning threshold LSB	*	RO
174		Custom monitor low warning threshold MSB	*	RO
175		Custom monitor low warning threshold LSB	*	RO
176	Lane-specific monitor thresholds	Tx optical power monitor high alarm threshold MSB	c3	RO
177		Tx optical power high alarm threshold LSB	c6	RO
178		Tx optical power low alarm threshold MSB	0a	RO
179		Tx optical power low alarm threshold LSB	0a	RO
180		Tx optical power high warning threshold MSB	62	RO
181		Tx optical power high warning threshold LSB	1e	RO
182		Tx optical power low warning threshold MSB	14	RO
183		Tx optical power low warning threshold LSB	08	RO
184		Tx bias current monitor high alarm threshold MSB	ff	RO
185		Tx bias current high alarm threshold LSB	ff	RO
186		Tx bias current low alarm threshold MSB	00	RO
187		Tx bias current low alarm threshold LSB	00	RO
188		Tx bias current high warning threshold MSB	ff	RO
189		Tx bias current high warning threshold LSB	ff	RO
190		Tx bias current low warning threshold MSB	00	RO

191		Tx bias current low warning threshold LSB	00	RO
192		Rx optical power monitor high alarm threshold MSB	c3	RO
193		Rx optical power high alarm threshold LSB	c6	RO
194		Rx optical power low alarm threshold MSB	03	RO
195		Rx optical power low alarm threshold LSB	90	RO
196		Rx optical power high warning threshold MSB	62	RO
197		Rx optical power high warning threshold LSB	1e	RO
198		Rx optical power low warning threshold MSB	07	RO
199		Rx optical power low warning threshold LSB	1b	RO
200	Reserved		00	RO
201				
202				
203				
204				
205				
206				
207				
208				
209				
210				
211				
212				
213				
214				
215				
216				
217				
218				
219				
220				
221				
222				
223				

224				
225				
226				
227				
228				
229				
230	Customizable space		00	RO
231				
232				
233				
234				
235				
236				
237				
238				
239				
240				
241				
242				
243				
244				
245				
246				
247				
248				
249				
250				
251				
252				
253				
254				
255	Checksum	Covers bytes 128-254	*	RO

Upper Memory Map Page 10h

data address	Name	Description	Value (hex)	Read/Write
128	Data Path Power control	DataPathPwrUp lane1 ~ 8	00	RW
129	Lane-Specific Control	Tx1~8 Polarity Flip	00	RW
130		TX Disable for media lane 1~8	00	RW
131		TX Squelch for media lane 1~8	FF	RW

132		TX Force Squelch for media lane 1~8	00	RW
133		reserved	00	RO
134		TX Input Eq Adaptation Freeze for lane 1~8	00	RW
135		TX1~4 Input Eq Adaptation Store	00	WO
136		TX5~8 Input Eq Adaptation Store	00	WO
137		Rx1~8 Polarity Flip	00	RW
138		RX Output Disable for 1~8	00	RW
139		RX Squelch Disable for 1~8	00	RW
140			00	
141		reserved	00	RO
142			00	
143	Staged Control Set 0	Staged Set 0 Lane 1~8 Apply_DataPathInit	00	WO
144		Staged Set 0 Lane 1~8 Apply_Immediate	00	WO
145		Staged Set 0 Lane 1 Application code/Data Path code/Explicit Control	11	RW
146		Staged Set 0 Lane 2 Application code/Data Path code/Explicit Control	11	
147		Staged Set 0 Lane 3 Application code/Data Path code/Explicit Control	11	
148		Staged Set 0 Lane 4 Application code/Data Path code/Explicit Control	11	
149		Staged Set 0 Lane 5 Application code/Data Path code/Explicit Control	11	
150		Staged Set 0 Lane 6 Application code/Data Path code/Explicit Control	11	
151		Staged Set 0 Lane 7 Application code/Data Path code/Explicit Control	11	
152		Staged Set 0 Lane 8 Application code/Data Path code/Explicit Control	11	

153	Staged Set 0 Tx1~8 Adaptive Input Eq Enable	FF	
154	Staged Set 0 Tx1~4 Adaptive Input Eq Recall	00	
155	Staged Set 0 Tx5~8 Adaptive Input Eq Recall	00	
156	Staged Set 0 Tx1~2 Input Eq control	00	
157	Staged Set 0 Tx3~4 Input Eq control	00	
158	Staged Set 0 Tx5~6 Input Eq control	00	
159	Staged Set 0 Tx7~8 Input Eq control	00	
160	Staged Set 0 Tx1~8 CDR control	FF	
161	Staged Set 0 Rx1~8 CDR control	FF	
162	Staged Set 0 Rx1~2 Output Eq control, pre-cursor	00	
163	Staged Set 0 Rx3~4 Output Eq control, pre-cursor	00	
164	Staged Set 0 Rx5~6 Output Eq control, pre-cursor	00	
165	Staged Set 0 Rx7~8 Output Eq control, pre-cursor	00	
166	Staged Set 0 Rx1~2 Output Eq control, post-cursor	00	
167	Staged Set 0 Rx3~4 Output Eq control, post-cursor	00	
168	Staged Set 0 Rx5~6 Output Eq control, post-cursor	00	
169	Staged Set 0 Rx7~8 Output Eq control, post-cursor	00	
170	Staged Set 0 Rx1~2 Output Amplitude control	*	
171	Staged Set 0 Rx3~4 Output Amplitude control	*	
172	Staged Set 0 Rx5~6 Output Amplitude control	*	
173	Staged Set 0 Rx7~8 Output Amplitude control	*	
174	reserved	00	RO
175		00	

176			00	
177			00	
178		Staged Set 1 Lane 1~8 Apply_DataPathInit	00	WO
179		Staged Set 1 Lane 1~8 Apply_Immediate	00	WO
180		Staged Set 1 Lane 1 Application code/Data Path code/Explicit Control	00	RW
181		Staged Set 1 Lane 2 Application code/Data Path code/Explicit Control	00	
182		Staged Set 1 Lane 3 Application code/Data Path code/Explicit Control	00	
183		Staged Set 1 Lane 4 Application code/Data Path code/Explicit Control	00	
184		Staged Set 1 Lane 5 Application code/Data Path code/Explicit Control	00	
185	Staged Control Set 1	Staged Set 1 Lane 6 Application code/Data Path code/Explicit Control	00	
186		Staged Set 1 Lane 7 Application code/Data Path code/Explicit Control	00	
187		Staged Set 1 Lane 8 Application code/Data Path code/Explicit Control	00	
188		Staged Set 1 Tx1~8 Adaptive Input Eq Enable	00	
189		Staged Set 1 Tx1~4 Adaptive Input Eq Recall	00	
190		Staged Set 1 Tx5~8 Adaptive Input Eq Recall	00	
191		Staged Set 1 Tx1~2 Input Eq control	00	
192		Staged Set 1 Tx3~4 Input Eq control	00	
193		Staged Set 1 Tx5~6 Input Eq control	00	

194		Staged Set 1 Tx7~8 Input Eq control	00	
195		Staged Set 1 Tx1~8 CDR control	00	
196		Staged Set 1 Rx1~8 CDR control	00	
197		Staged Set 1 Rx1~2 Output Eq control, pre-cursor	00	
198		Staged Set 1 Rx3~4 Output Eq control, pre-cursor	00	
199		Staged Set 1 Rx5~6 Output Eq control, pre-cursor	00	
200		Staged Set 1 Rx7~8 Output Eq control, pre-cursor	00	
201		Staged Set 1 Rx1~2 Output Eq control, post-cursor	00	
202		Staged Set 1 Rx3~4 Output Eq control, post-cursor	00	
203		Staged Set 1 Rx5~6 Output Eq control, post-cursor	00	
204		Staged Set 1 Rx7~8 Output Eq control, post-cursor	00	
205		Staged Set 1 Rx1~2 Output Amplitude control	00	
206		Staged Set 1 Rx3~4 Output Amplitude control	00	
207		Staged Set 1 Rx5~6 Output Amplitude control	00	
208		Staged Set 1 Rx7~8 Output Amplitude control	00	
209				
210		reserved	00	RO
211				
212				
213	Lane-Specific Flag Masks	M-Lane 1~8 Data Path State Changed flag mask	00	RW
214		M-Tx1~8 Fault flag mask	00	RW
215		M-Tx1~8 LOS flag mask	00	RW
216		M-Tx1~8 CDR LOL flag mask	00	RW
217		M-Tx1~8 Adaptive Eq Fault flag mask	00	RW
218		M-Tx1~8 Power High Alarm flag mask	00	RW
219		M-Tx1~8 Power Low Alarm flag	00	RW

		mask		
220		M-Tx1~8 Power High Warning flag mask	00	RW
221		M-Tx1~8 Power Low Warning flag mask	00	RW
222		M-Tx1~8 Bias High Alarm flag mask	00	RW
223		M-Tx1~8 Bias Low Alarm flag mask	00	RW
224		M-Tx1~8 Bias High Warning flag mask	00	RW
225		M-Tx1~8 Bias Low Warning flag mask	00	RW
226		M-Rx1~8 LOS flag mask	00	RW
227		M-Rx1~8 CDR LOL flag mask	00	RW
228		M-Rx1~8 Power High Alarm flag mask	00	RW
229		M-Rx1~8 Power Low Alarm flag mask	00	RW
230		M-Rx1~8 Power High Warning flag mask	00	RW
231		M-Rx1~8 Power Low Warning flag mask	00	RW
232	Reserved		00	RO
233				
234				
235				
236				
237				
238				
239				
240	Custom		00	RO
241				
242				
243				
244				
245				
246				
247				
248				
249				
250				

251				
252				
253				
254				
255				

Upper Memory Map Page 11h

data address	Name	Description	Value (hex)	Read/Write
128	Datapath State indicators	Data path state encoding for lane 1~2	*	RO
129		Data path state encoding for lane 3~4	*	RO
130		Data path state encoding for lane 5~6	*	RO
131		Data path state encoding for lane 7~8	*	RO
132	reserved		00	RO
133				
134	Lane-specific flags	Latched Data Path State Changed flag for lane 1~8	*	RO
135		Latched Tx Fault flag, media lane 1~8	*	RO
136		Latched Tx LOS flag, lane 1~8	*	RO
137		Latched Tx CDR LOL flag, lane 1~8	*	RO
138		Latched Tx Adaptive Input Eq. Fault Lane 1~8	*	RO
139		Tx output power High Alarm, media lane 1~8	*	RO
140		Tx output power Low alarm, media lane 1~8	*	RO
141		Tx output power High warning, media lane 1~8	*	RO
142		Tx output power High warning, media lane 1~8	*	RO
143		Tx Bias High Alarm, media lane 1~8	*	RO
144		Tx Bias Low alarm, media lane 1~8	*	RO
145		Tx Bias High warning, media lane 1~8	*	RO

146		Tx Bias Low warning, media lane 1~8	*	RO
147		Latched Rx LOS flag, media lane 1~8	*	RO
148		Latched Rx CDR LOL flag, media lane 1~8	*	RO
149		Rx input power High alarm, media lane 1~8	*	RO
150		Rx input power Low alarm, media lane 1~8	*	RO
151		Rx input power High warning, media lane 1~8	*	RO
152		Rx input power Low warning, media lane 1~8	*	RO
153	reserved		00	RO
154	Lane-specific monitors	Tx1 Power MSB	*	RO
155		Tx1 Power LSB	*	RO
156		Tx2 Power MSB	*	RO
157		Tx2 Power LSB	*	RO
158		Tx3 Power MSB	*	RO
159		Tx3 Power LSB	*	RO
160		Tx4 Power MSB	*	RO
161		Tx4 Power LSB	*	RO
162		Tx5 Power MSB	*	RO
163		Tx5 Power LSB	*	RO
164		Tx6 Power MSB	*	RO
165		Tx6 Power LSB	*	RO
166		Tx7 Power MSB	*	RO
167		Tx7 Power LSB	*	RO
168		Tx8 Power MSB	*	RO
169		Tx8 Power LSB	*	RO
170			Tx1 Bias MSB	*
171		Tx1 Bias LSB	*	RO
172		Tx2 Bias MSB	*	RO
173		Tx2 Bias LSB	*	RO
174		Tx3 Bias MSB	*	RO
175		Tx3 Bias LSB	*	RO
176		Tx4 Bias MSB	*	RO
177		Tx4 Bias LSB	*	RO
178		Tx5 Bias MSB	*	RO
179		Tx5 Bias LSB	*	RO
180		Tx6 Bias MSB	*	RO

181		Tx6 Bias LSB	*	RO
182		Tx7 Bias MSB	*	RO
183		Tx7 Bias LSB	*	RO
184		Tx8 Bias MSB	*	RO
185		Tx8 Bias LSB	*	RO
186		Rx1 Power MSB	*	RO
187		Rx1 Power LSB	*	RO
188		Rx2 Power MSB	*	RO
189		Rx2 Power LSB	*	RO
190		Rx3 Power MSB	*	RO
191		Rx3 Power LSB	*	RO
192		Rx4 Power MSB	*	RO
193		Rx4 Power LSB	*	RO
194		Rx5 Power MSB	*	RO
195		Rx5 Power LSB	*	RO
196		Rx6 Power MSB	*	RO
197		Rx6 Power LSB	*	RO
198		Rx7 Power MSB	*	RO
199		Rx7 Power LSB	*	RO
200		Rx8 Power MSB	*	RO
201		Rx8 Power LSB	*	RO
202	Configuration Error Codes	Configuration Error Code for lane 1~2	*	RO
203		Configuration Error Code for lane 3~4	*	RO
204		Configuration Error Code for lane 5~6	*	RO
205		Configuration Error Code for lane 7~8	*	RO
206	Active Control Set	Active Set Lane 1 Application code/Data Path code/Explicit Control	*	RO
207		Active Set Lane 2 Application code/Data Path code/Explicit Control	*	RO
208		Active Set Lane 3 Application code/Data Path code/Explicit Control	*	RO
209		Active Set Lane 4 Application code/Data Path code/Explicit Control	*	RO

210	Active Set Lane 5 Application code/Data Path code/Explicit Control	*	RO
211	Active Set Lane 6 Application code/Data Path code/Explicit Control	*	RO
212	Active Set Lane 7 Application code/Data Path code/Explicit Control	*	RO
213	Active Set Lane 8 Application code/Data Path code/Explicit Control	*	RO
214	Active Set Tx1~8 Adaptive Input Eq Enable	*	RO
215	Active Set Tx1~4 Adaptive Input Eq Recall	*	RO
216	Active Set Tx5~8 Adaptive Input Eq Recall	*	RO
217	Active Set Tx1~2 Input Eq control	*	RO
218	Active Set Tx3~4 Input Eq control	*	RO
219	Active Set Tx5~6 Input Eq control	*	RO
220	Active Set Tx7~8 Input Eq control	*	RO
221	Active Set Tx1~8 CDR control	*	RO
222	Active Set Rx1~8 CDR control	*	RO
223	Active Set Rx1~2 Output Eq control, pre-cursor	00	RO
224	Active Set Rx3~4 Output Eq control, pre-cursor	00	RO
225	Active Set Rx5~6 Output Eq control, pre-cursor	00	RO
226	Active Set Rx7~8 Output Eq control, pre-cursor	00	RO
227	Active Set Rx1~2 Output Eq control, post-cursor	00	RO
228	Active Set Rx3~4 Output Eq control, post-cursor	00	RO
229	Active Set Rx5~6 Output Eq control, post-cursor	00	RO

230		Active Set Rx7~8 Output Eq control, post-cursor	00	RO
231		Active Set Rx1~2 Output Amplitude control	*	RO
232		Active Set Rx3~4 Output Amplitude control	*	RO
233		Active Set Rx5~6 Output Amplitude control	*	RO
234		Active Set Rx7~8 Output Amplitude control	*	RO
235	reserved		00	RO
236				RO
237				RO
238				RO
239				RO
240	Host Electrical to Module Media Lane Mapping	Module TX media lane 1 wavelength/fiber mapping	*	RO
241		Module TX media lane 2 wavelength/fiber mapping	*	RO
242		Module TX media lane 3 wavelength/fiber mapping	*	RO
243		Module TX media lane 4 wavelength/fiber mapping	*	RO
244		Module TX media lane 5 wavelength/fiber mapping	*	RO
245		Module TX media lane 6 wavelength/fiber mapping	*	RO
246		Module TX media lane 7 wavelength/fiber mapping	*	RO
247		Module TX media lane 8 wavelength/fiber mapping	*	RO
248		Module RX media lane 1 wavelength/fiber mapping	*	RO
249		Module RX media lane 2 wavelength/fiber mapping	*	RO
250		Module RX media lane 3 wavelength/fiber mapping	*	RO
251		Module RX media lane 4 wavelength/fiber mapping	*	RO
252		Module RX media lane 5 wavelength/fiber mapping	*	RO

253		Module RX media lane 6 wave-length/fiber mapping	*	RO
254		Module RX media lane 7 wave-length/fiber mapping	*	RO
255		Module RX media lane 8 wave-length/fiber mapping	*	RO

Digital Diagnostic Monitoring Functions

support the I2C-based Diagnostic Monitoring Interface (DMI) defined in document SFF-8636. The host can access real-time performance of trans-mitter and receiver optical power, temperature, supply voltage and bias current.

Performance Item	Related Bytes(A0[00] memory)	Monitor Error	Notes
Module temperature	22 to 23	+/-3 °C	1, 2
Module voltage	26 to 27	< 3%	2
LD Bias current	42 to 43	< 10%	2
Transmitter optical power	50 to 51	< 3dB	2
Receiver optical power	34 to 35	< 3dB	2

Note

- 1, Actual temperature test point is fixed on module case around Laser.
- 2, Full operating temperature range

Alarm and Warning Thresholds

support alarms function, indicating the values of the pre-ceeding basic performance are lower or higher than the thresholds.

Performance Item	Alarm Threshold Bytes(A0[03] memory)	Unit	Low threshold	High threshold
Temp Alarm	128 to 131	°C	-10	80
Temp Warning	132 to 135	°C	0	70
Voltage Alarm	144 to 147	V	2.97	3.63
Voltage Warning	148 to 151	V	3.135	3.465

TX Power Alarm	192 to 195	dBm	-6.3	6.5
TX Power Warning	196 to 199	dBm	-3.3	3.5
RX Power Alarm	176 to 179	dBm	-10.6	6.5
RX Power Warning	180 to 183	dBm	-7.6	3.5

Mechanical Specifications

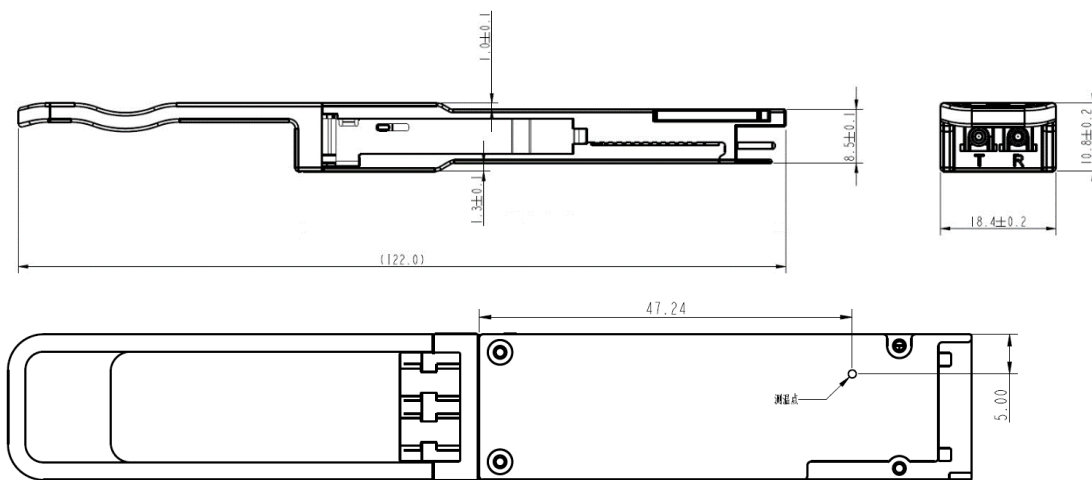

Figure 5. Mechanical Dimensions

Regulatory Compliance

Optical Transceiver is RoHS 6/6 compliant and complies with international electromagnetic compatibility (EMC) and product safety requirements and standards.

Feature	Standard	Performance
Safety		
UL	UL 62368-1	UL recognized component for US and CAN
	CAN/CSA C22.2 No. 62368-1-14	
TUV	EN 60950-1	TUV certificate
	EN/IEC 60825-1:2007, Edition 2	
	EN/IEC 60825-1:2014, Edition 3	

	EN/IEC 60825-2:2004+A1:2006+A2:2010	
FDA	U.S. 21 CFR 1040.10	FDA/CDRH certified with accession number according to Laser Notice 50
Electromagnetic Compatibility		
Radiated emissions	EMC Directive 2014/30/EU	Class B digital device with a minimum -6dB margin to the limit when tested with a metal enclosure. Final margin may vary depending on system application, good system EMI design practice, ie: suitable metal enclosure and well-bonding, is required to achieve Class B margins at the system level. Tested frequency range: 30 MHz to 40 GHz or 5th harmonic (5 times the highest frequency), whichever is less.
	EN 55032	
	CISPR 32	
	FCC rules 47 CFR Part 15	
	ICES-003	
	AS/NZS CISPR 32	
ESD	EN 55024	Withstands discharges of ± 8 k V contact, ± 15 k V air.
	CISPR 24	
	IEC/EN 61000-4-2	
Radiated immunity	EN 55024	Field strength of 10 V/m from 80 MHz to 6 GHz.
	CISPR 24	
	IEC/EN 61000-4-3	
Restriction of Hazardous Substances		
RoHS	EU Directive 2011/65/EU (EU) 2015/863	

ESD Design

Normal ESD precautions are required during the handling of this module. This transceiver is shipped in ESD protective packaging. It should be removed from the packaging and otherwise handled in an ESD protected environment utilizing standard grounded benches, floor mats, and wrist straps.

Parameter	Threshold value	Notes
ESD of high-speed pins	1KV	Human Body Model
ESD of low-speed pins	2KV	Human Body Model
Air discharge during operation	15KV	
Direct contact discharges to the case	8KV	

Safety Specification Design



Cautions

Do not look into fiber end faces without eye protection using an optical meter (such as magnifier and microscope) within 100 mm, unless you ensure that the laser output is disabled.

When operating an optical meter, observe the operation requirements.

CAUTION: Use of controls or adjustments or performance of procedures other than those specified herein may result in hazardous radiation exposure.
