

THIS DRAWING AND SPECIFICATIONS HEREIN ARE THE PROPERTY OF ENCONNEX LLC. AND SHALL NOT BE COPIED, REPRODUCED OR USED IN WHOLE OR IN PART, AS THE BASIS FOR THE MANUFACTURE OR SALE OF ITEMS WITHOUT THE WRITTEN PERMISSION OF ENCONNEX LLC. THIS DRAWING IS SUBJECT TO CHANGE WITHOUT NOTICE.

REVISIONS			
REV	DESCRIPTION	DATE	APPROVED
A	FULL RELEASED	2022.2.11	FANCY FAN

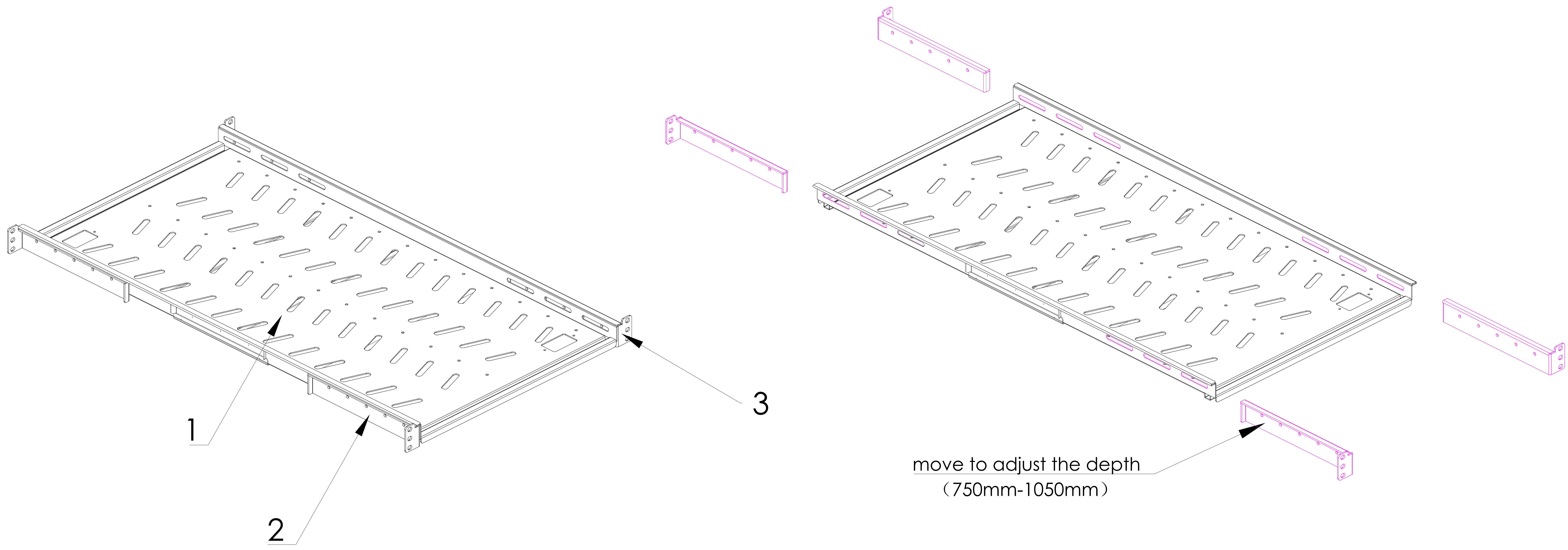

NOTES, UNLESS OTHERWISE SPECIFIED:

- MATERIAL: CRS.
- FINISH: POWDERCOAT RAL9005. ALL SURFACES EXCEPT WHERE NOTED INCLUDING PEM HEADS, MASK STANDOFFS AND THREADS; REMOVE MASK PRIOR TO SHIPPING. ALL DIMS PRE-FINISH.  
WHERE INDICATED MASK BEFORE POWDERCOAT. FINISH WITH CONDUCTIVE PAINT.
- PART MUST BE SUFFICIENTLY FREE OF BURRS AND SHARP EDGES TO PASS UL 1439 SHARP EDGE TEST.
- ALL PARTS TO BE FREE OF DIRT OR GRIME THAT PREVENTS LABEL ADHESION OR ALLOWS TRANSFER ONTO COSMETIC AREAS.
- 3D CAD AVAILABLE IN ADDITION TO PDF PRINT. SHOULD DISCREPANCY ARISE, CONSULT ENCONNEX ENGINEERING IMMEDIATELY.
- MUST BE ROHS COMPLIANT, INCLUDING HARDWARE.
- DIMENSIONS IDENTIFIED WITH (X.XX) ARE CONSIDERED CRITICAL TO QUALITY (CTQ) DIMENSIONS. THESE DIMENSIONS ARE EXPECTED TO BE MONITORED STATISTICALLY AND DOCUMENTED AS PART OF THE FABRICATION PROCESS.
- 1.0MM STRAIGHTNESS AT EDGES. 1.0MM FLATNESS FOR SURFACES LESS THAN 150MM IN EITHER DIRECTION. 3.0MM FLATNESS FOR LARGER SURFACES. 90° BENDS ARE ±0.5°.

ITEM	PN	DES	PCS
1	1M2-W008	Bottom plate	1
2	1M2-W006	Hanging ears 1	2
3	1M2-W007	Hanging ears 2	2
4	OK0-W010	Accessories Bag	1

UNLESS NOTED, DIMENSIONS IN MILLIMETERS & TOLERANCES ARE: X. ±1 MM X° ±1° X.X ±0.5 MM X.X° ±0.5° X.XX ±0.20 MM ØX.X ±0.3 MM ØX.XX ±0.10 MM		PRODUCT LINE: 4 POST FIX SHELF	
		PART NUMBER: ECX-FSF-H850	
4670 AIRCENTER CIRCLE, RENO, NV89502		DESCRIPTION: Fix shelf, for 4 post cabinet, 1U, 850mm D, for 750-1000mm mounting rail distance, 400lbs	
	DRAWING FILE NAME ECX-FSF-H850	ENGINEER: WAYNE WANG	ORG DATE: 2022.2.11
	3D MODEL FILE NAME ECX-FSF-H850	DRAWN: WAYNE WANG	REV DATE: 2022.2.11
THIRD ANGLE PROJECTION	3D MODEL CONFIGURATION	ITEM WEIGHT (REFERENCE ONLY)	REV: A
UNITS: MM(IN)	INTERPRET TO ASME Y14.100	SIZE: A	SCALE: 1:1 DO NOT SCALE DRAWING SHEET: 1/2

THIS DRAWING AND SPECIFICATIONS HEREIN ARE THE PROPERTY OF ENCONNEX LLC. AND SHALL NOT BE COPIED, REPRODUCED OR USED IN WHOLE OR IN PART, AS THE BASIS FOR THE MANUFACTURE OR SALE OF ITEMS WITHOUT THE WRITTEN PERMISSION OF ENCONNEX LLC. THIS DRAWING IS SUBJECT TO CHANGE WITHOUT NOTICE.

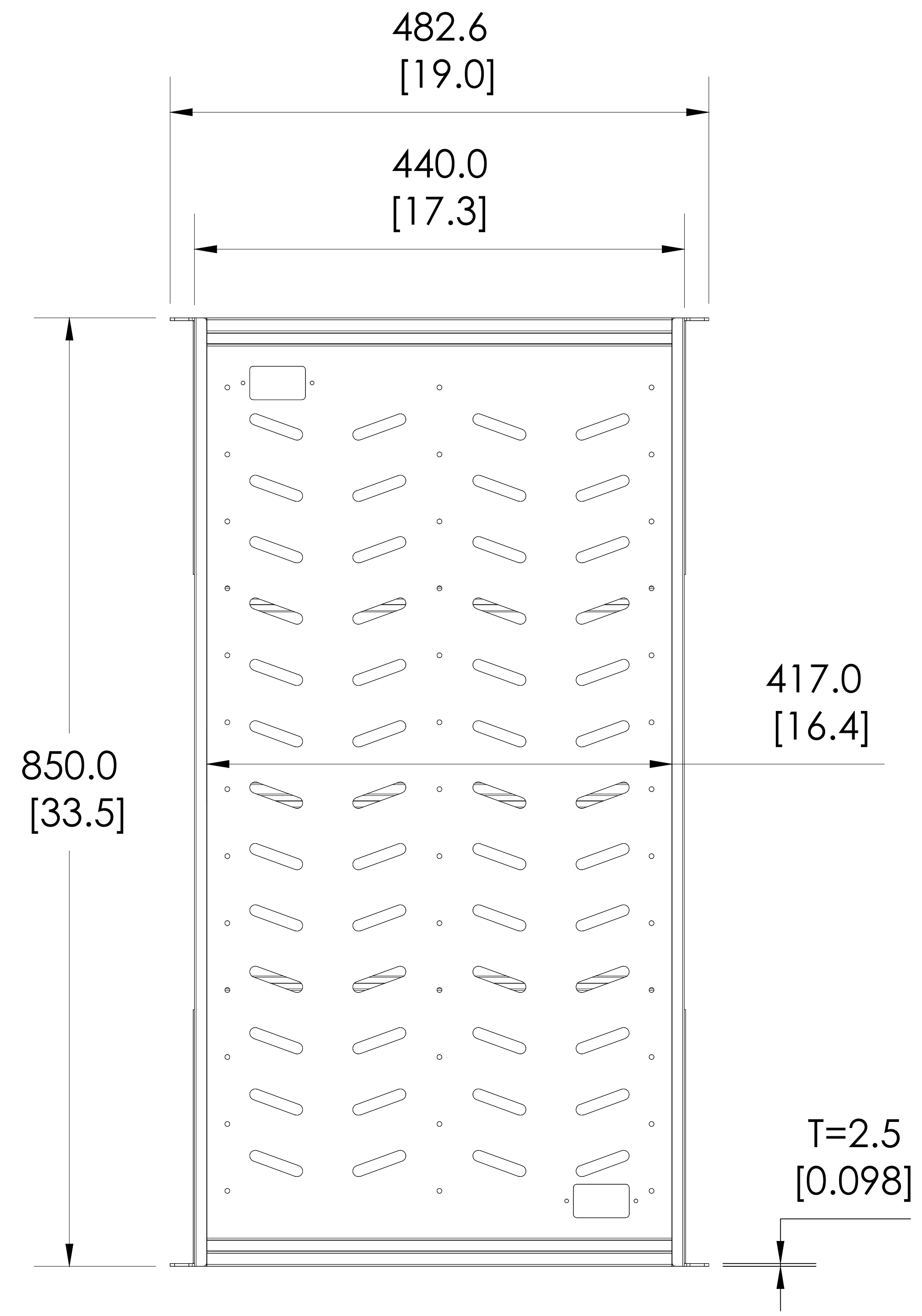

TOP VIEW

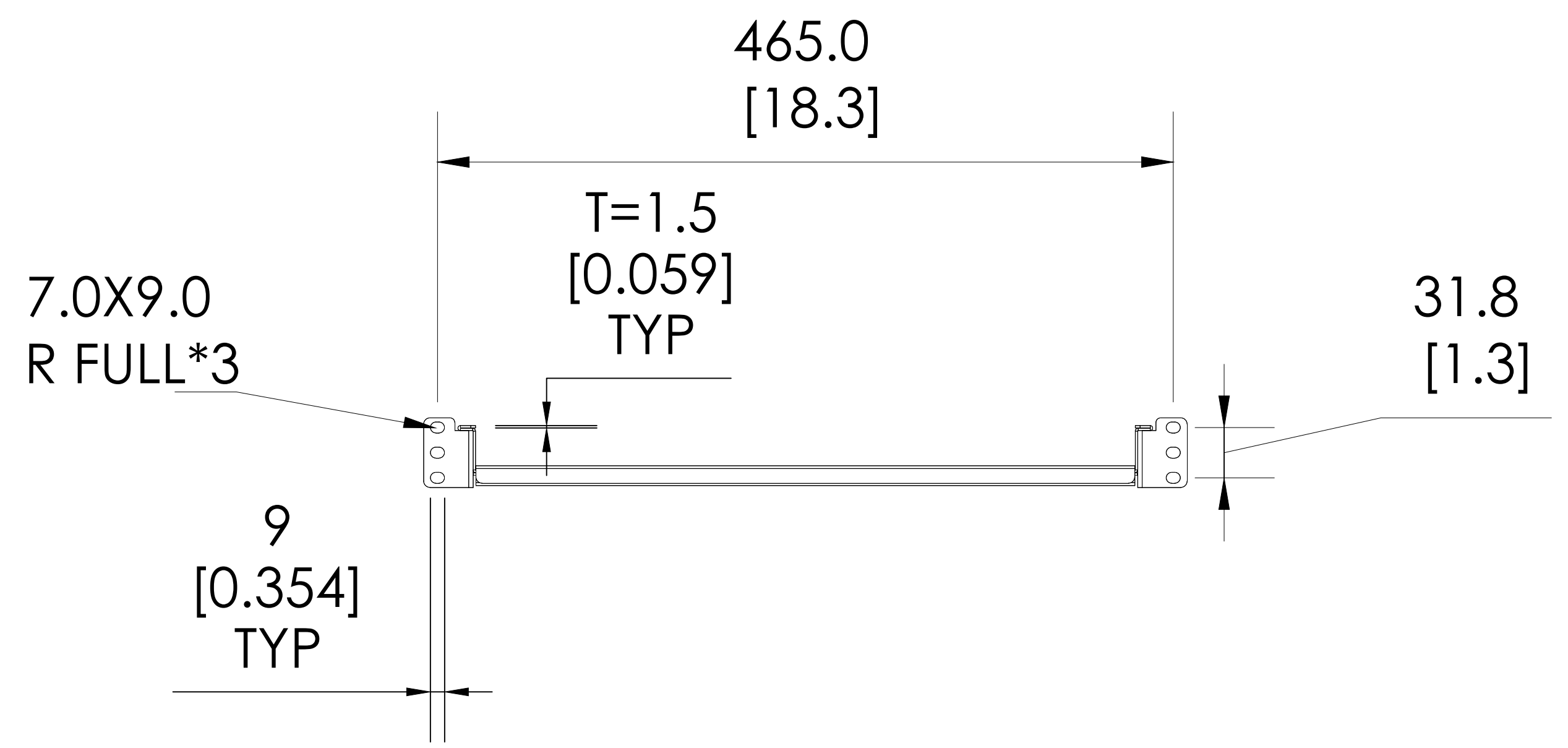

FRONT VIEW

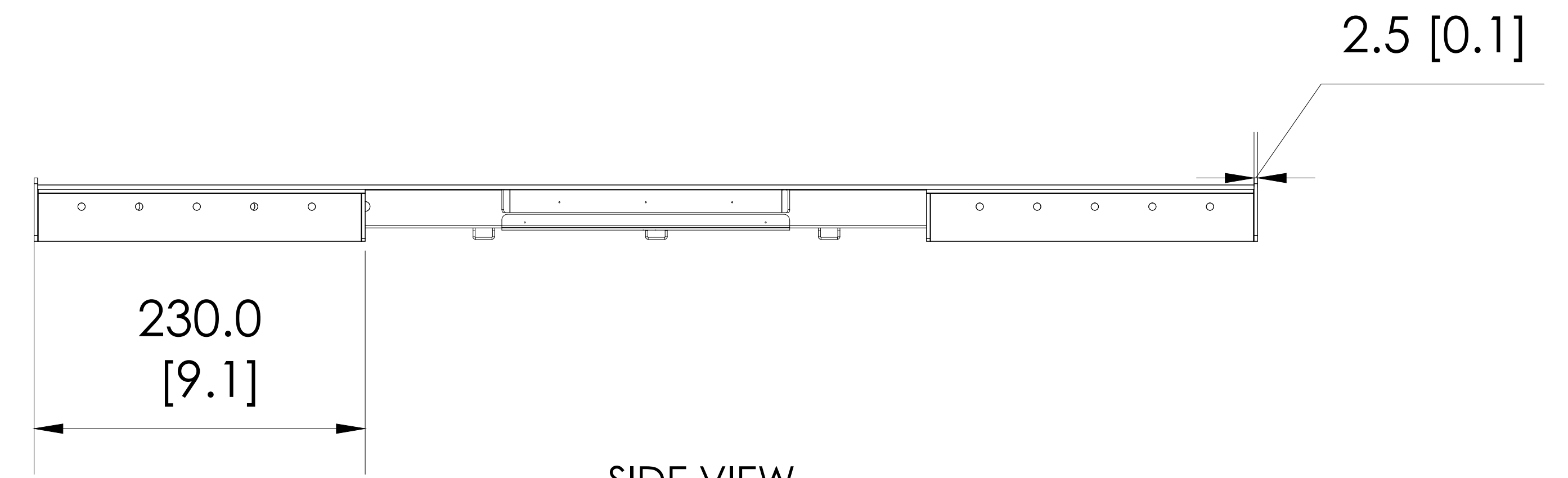
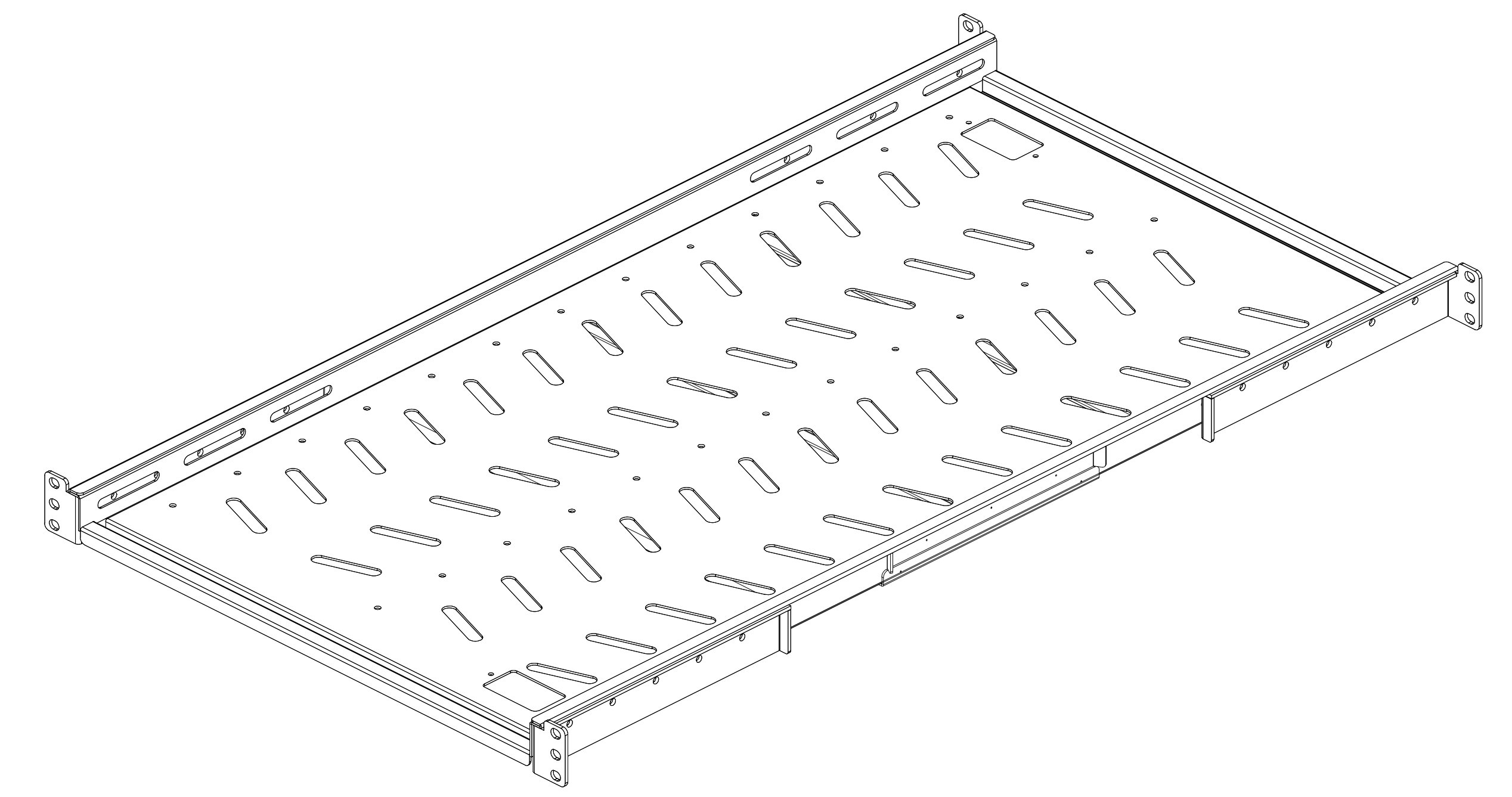

SIDE VIEW

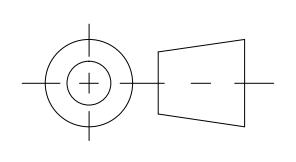
UNLESS NOTED, DIMENSIONS IN MILLIMETERS & TOLERANCES ARE:		 <b>ENCONNEX</b> 4670 AIRCENTER CIRCLE, RENO, NV89502	PRODUCT LINE: 4 POST FIX SHELF
X. ± 1 MM	X° ± 1°		PART NUMBER: ECX-FSF-H850
X.X ± 0.5 MM	X.X° ± 0.5°		DESCRIPTION: Fix shelf, for 4 post cabinet, 1U, 850mm D, for 750-1000mm mounting rail distance, 400lbs
X.XX ± 0.20 MM			
ØX.X ± 0.3 MM			
ØX.XX ± 0.10 MM			
 THIRD ANGLE PROJECTION	DRAWING FILE NAME ECX-FSF-H850	ENGINEER:WAYNE WANG	ORG DATE:2022.2.11
	3D MODEL FILE NAME ECX-FSF-H850	DRAWN:WAYNE WANG	REV DATE:2022.2.11
	3D MODEL CONFIGURATION	ITEM WEIGHT (REFERENCE ONLY)	REV:A
UNITS:MM(IN)	INTERPRET TO ASME Y14.100	SIZE: A	SCALE:1:1
		DO NOT SCALE DRAWING	SHEET:2/2