

40Gbps QSFP+ LR4 Optical Transceiver

ALQ10-LR4-10

Features

- Support up to 11.3Gbps per channel
- QSFP+ MAS compliant
- Compliant with QDR/DDR Infiniband data rates
- Maximum link length of 10km SMF
- Hot pluggable electrical interface
- +3.3V power supply
- Operating case temperature range 0~70°C
- RoHS 6 Compliant
- LC duplex connector
- Maximum power consumptions: 2.5W



Applications

- 40GBASE-LR4 40G Ethernet Links
- Infiniband QDR and DDR interconnects
- Client-side 40G Datacom connections

Performance Specifications

Absolute Maximum Ratings

These values represent the damage threshold of the module. Stress in excess of any of the individual absolute maximum ratings can cause immediate catastrophic damage to the module even if all other parameters are within recommended Operating conditions

Table.1 Absolute maximum ratings

Parameter	Symbol	Min.	Max.	Unit
Storage Temperature	T _s	-40	85	C
Operating Case Temperature	T _{op}	0	70	C
Power supply Voltage	V _{cc}	0	3.6	V
Relative Humidity	RH	0	85	%
Maximum Optical Input Power	P _{in}	-5	0	dBm

Recommended Operating Conditions

Table.2 Recommended Operating Conditions

Parameter	Symbol	Min.	Typ.	Max.	Unit
Operating Case Temperature	T _c	0		70	°C
Power Supply Voltage	V _{cc}	3.14	3.3	3.47	V
Power Supply Current	I _{cc}			1000	mA
Power Dissipation	PD			2.5	W
Data Rate per Lane	DR		10.3125	11.3	Gbps
Link Distance on SMF			10		km

Transmitter Specification

Table.3 Transmitter Specification (Optical)_{off}

Parameter	Symbol	Min	Typ.	Max	Unit
Center wavelength	c0	1264.5		1277.5	nm
	c1	1284.5		1297.5	
	c2	1304.5		1317.5	
	c3	1324.5		1337.5	
Side-mode suppression Ratio	SMSR	30			dB
Extinction Ratio	ER	3.5	4.5		dB
Spectral Width	Δλ			1	nm

Average launch power	$P_{O,AVG}$	-7		+2.0	dBm
Optical Modulation Amplitude, each lane	OMA	-4		+3.5	dBm
Relative Intensity Noise	Rin			-128	dB/Hz
Optical Return Loss Tolerance				20	dB
Transmitter Reflectance	R_T			-12	dB
Transmitter Eye Mask Definition (X1,X2,X3, Y1, Y2, Y3)		Compliant with 802.3ba Standard(0.25,0.4,0.45,0.25,0.28,0.4)			
Average LaunchPower OFFTransmitter, each Lane	P_{off}			-30	dBm

Table.4 Transmitter Specification (Electrical)

Parameter	Symbol	Min.	Typ.	Max.	Unit
Supply Voltage	Vcc	3.14	3.3	3.47	V
Supply Current	Icc			1000	mA
Maximum Power Consumption				2.5	W
Data Rate per lane			10.3125	11.3	Gb/s
Differential Input Impedance			100		ohms

Receiver Specification

Table.5 Receiver Specification (optical)

Parameter	Symbol	Min.	Typ.	Max.	Unit
Center wavelength	c0	1264.5		1277.5	nm
	c1	1284.5		1297.5	
	c2	1304.5		1317.5	
	c3	1324.5		1337.5	
Damage Threshold				3.3	dBm
Overload			2.0		dBm
Receiver Reflectance				-26	dB
Receiver Sensitivity (OMA) per lane				-11.5	dBm
Stressed Receiver Sensitivity (OMA), each lane				-9.6	dBm

Table.6 Receiver Specification (Electrical)

Parameter	Symbol	Min.	Typ.	Max.	Unit
Differential Data Output Voltage Swing	Vout, p-p	200		850	mV
Output Differential Impedance	Rout		100		Ω

Pin Definition

The QSFP+ modules are hot-pluggable. Hot pluggable refers to plugging in or unplugging a module while the host board is powered. The QSFP+ hot connector is a 0.8mm pitch 38 position right angle improved connector specified by SFF-8436, or stacked connector with equivalent electrical performance. Host PCB contact assignment is shown in Figure 1 and contact definitions are given in Table below.

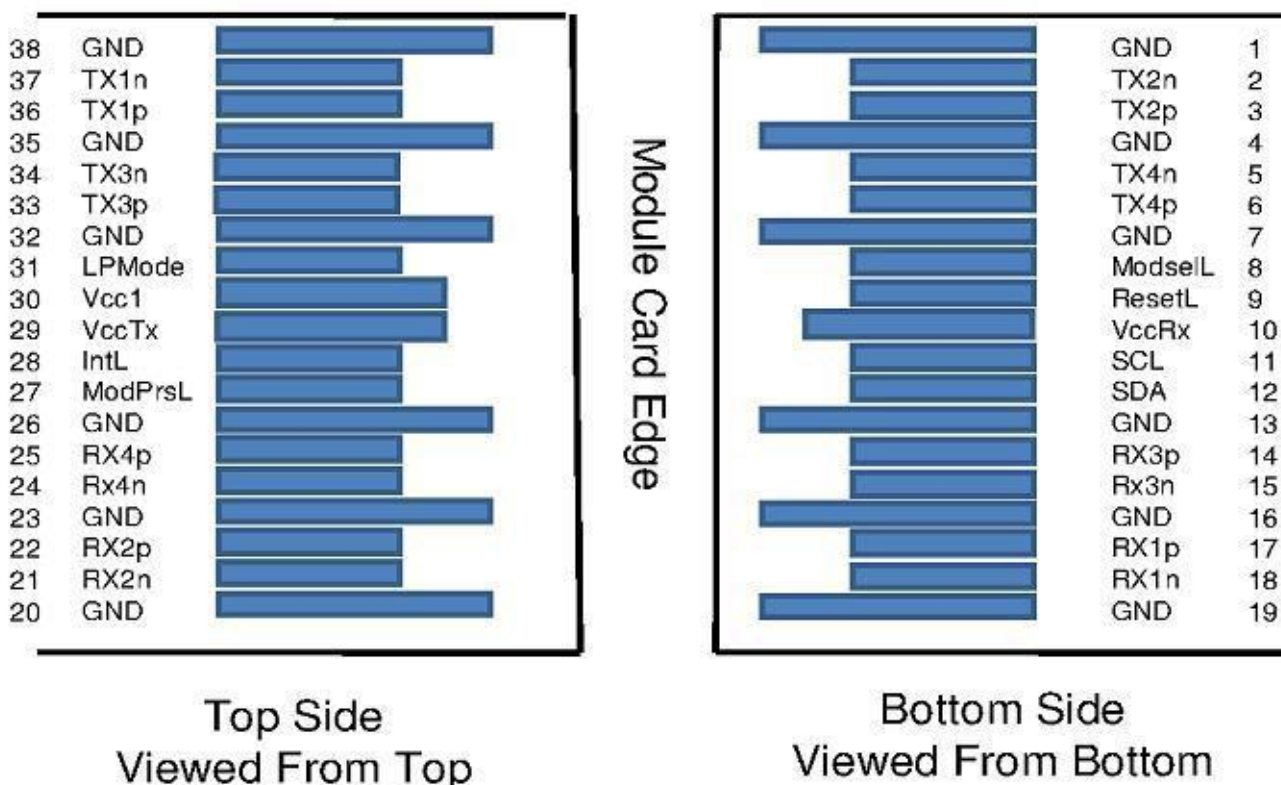

Figure 1: Interface to Host PCB

Pin	Logic	Symbol	Name/Description	Ref
1		GND	Module Ground	
2	CML-I	Tx2n	CH2 Transmitter Inverted Data Input	
3	CML-I	Tx2p	CH2 Transmitter Non-inverted Data Input	
4		GND	Module Ground	
5	CML-I	Tx4n	CH4 Transmitter Inverted Data Input	
6	CML-I	Tx4p	CH4 Transmitter Non-inverted Data Input	
7		GND	Module Ground	
8	LVTTL-I	ModSelL	Module Select	
9	LVTTL-I	ResetL	Module Reset	
10		VccRX	+3.3V Power Supply Receiver	
11	LVC MOS-I/O	SCL	2-wire serial interface cl'ck	
12	LVC MOS-I/O	SDA	2-wire serial interface data	
13		GND	Module Ground	
14	CML-O	Rx3p	CH3 Receiver Non-inverted Data Input	
15	CML-O	Rx3n	CH3 Receiver Inverted Data Input	
16		GND	Module Ground	
17	CML-O	Rx1p	CH1 Receiver Non-inverted Data Input	
18	CML-O	Rx1n	CH1 Receiver Inverted Data Input	
19		GND	Module Ground	
20		GND	Module Ground	
21	CML-O	Rx2n	CH2 Receiver Inverted Data Input	
22	CML-O	Rx2p	CH2 Receiver Non-inverted Data Input	
23		GND	Module Ground	
24	CML-O	Rx4n	CH4 Receiver Inverted Data Input	
25	CML-O	Rx4p	CH4 Receiver Non-inverted Data Input	
26		GND	Module Ground	
27	LVTTL-O	ModPrsL	Module Present	
28	LVTTL-O	IntL	Interrupt	
29		VccTX	+3.3V Power Supply Transmitter	
30		Vcc1	+3.3V Power Supply	

31	LVTTL-I	LPMode	Low Power Mode
32		GND	Module Ground
33	CML-I	Tx3p	CH3 Transmitter Non-inverted Data Input
34	CML-I	Tx3n	CH3 Transmitter Inverted Data Input
35		GND	Module Ground
36	CML-I	Tx1p	CH1 Transmitter Non-inverted Data Input
37	CML-I	Tx1n	CH1 Transmitter Inverted Data Input
38		GND	Module Ground

Note:

1. Module circuit ground is isolated from module chassis ground within the module
2. Open collector, should be pulled up with 4.7K-10K ohms on the host board to a voltage between 3.15V and 3.6V.

Timing Electrical Interface

Item	Parameter	Symbol	Min	Max	Units	Conditions
1	Time to initialize	t_init		2000	ms	Time from power on, hot plug or reset until the module is fully functional.
2	Reset Assert Time	t_reset		2000	ms	Time from rising edge on the ResetL pin until the modules is fully functional
3	IntL Assert Time	ton_IntL		200	ms	From occurrence of fault to assertion of IntL
4	IntL Negate Time	toff_IntL		500	us	Time t_reset must be held low to reset IntL.
5	LPMode Assert Time	ton_LPMode		100	us	Time for assertion of LPMode until module power consumption reached power level 1.
6	LPMode Negate Time	toff_LPMode		100	us	Time for deassertion of LPMode until module is fully functional

2-wire Management Interface

The transceivers provide management two-wire interface and the management memory map is specified by SFF-8436.

2-Wire Serial Address: 1010000x

0	ID and status	(3 Bytes)
2		
21	Interrupt Flags	(19 Bytes)
33		
33	Module Monitors	(12 Bytes)
81		
81	Channel Monitors	(48 Bytes)
85		
85	Reserved	(4 Bytes)
97	Control	(12 Bytes)
99	Reserved	(2 Bytes)
106	Free Side Device and Channel Mask	(7 Bytes)
107		
107	Reserved	(1 Bytes)
111	Free Side Device Properties	(4 Bytes)
118	Reserved	(7 Bytes)
122	Password Change Entry Area (Optional)	(4 Bytes)
126	Password Entry Area (Optional)	(4 Bytes)
127	Page Select Byte	(1 Bytes)

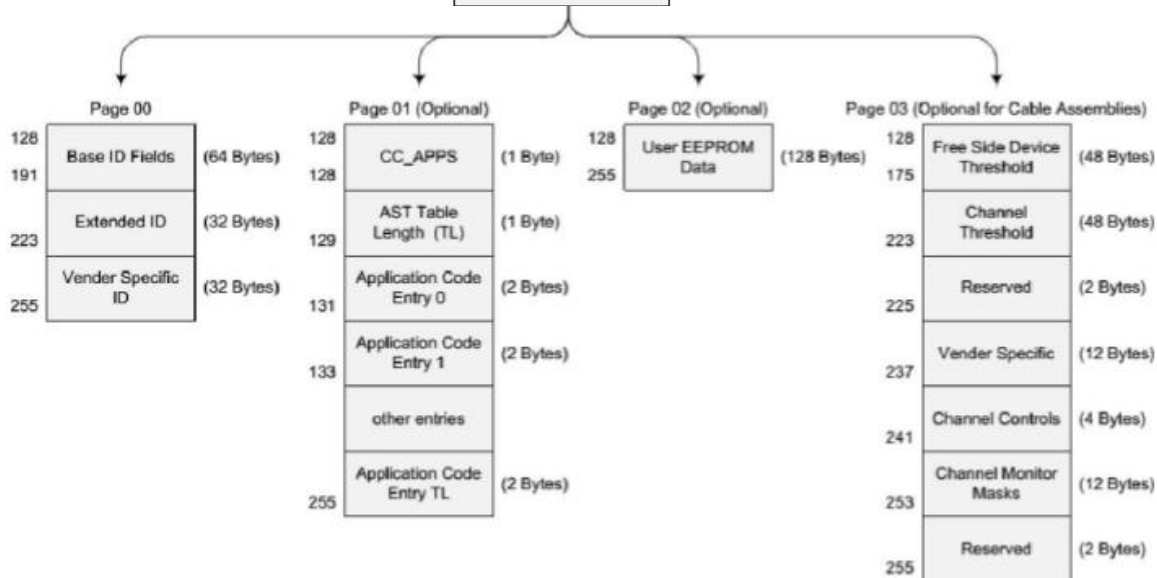

Mechanical

Package Dimensions (Unit: mm)

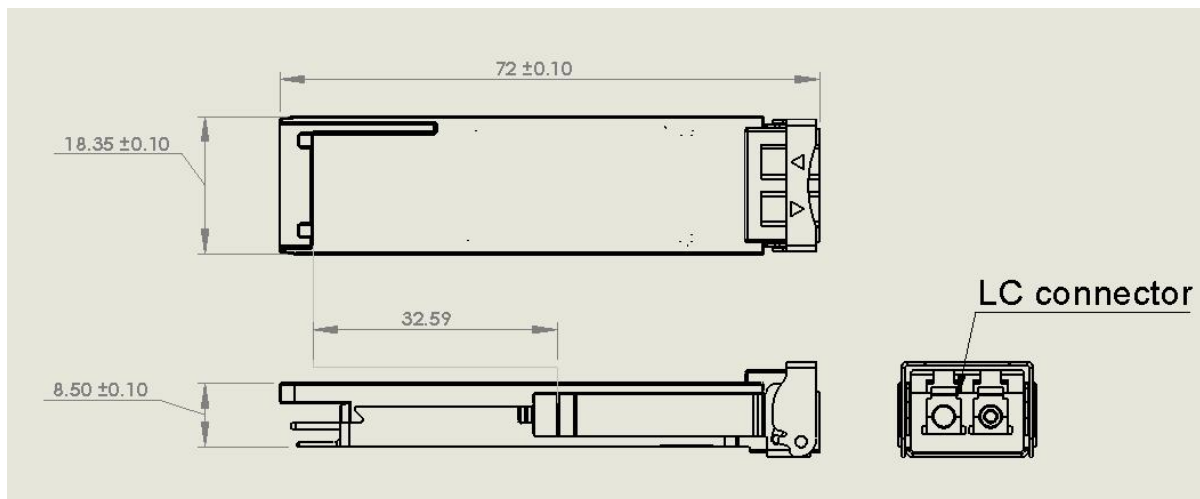

Application Cautions

ESD

This module high speed pins withstand 1KV electrostatic discharge on Human Body Model per JESD22-A114. The exception of high speed pins withstand 2KV electrostatic discharge based on Human Body Model per JESD 22-A114. The QSFP+ module meet ESD requirement in EN61000-4-2, criterion B test specification. The transceiver is shipped in ESD protective packaging. It should be removed from the packaging and handled only in an ESD protected environment.

Order Information

Part Number	Product Description
ALQ10-LR4-10	1310nm 40Gbps QSFP+ LR4 ,10km ,0°C ~70°C

Revision History

Revision	Initiated	Approved	content	Release Date
Ver1.0	Jacky	Nicky	Released	Dec/2016
Ver1.1	QR.HUANG	Nicky	Released	Jun/2017
Ver1.2	HT.HUANG	Nicky	Released	Nov/2017