

EdgeRack 3P Series Micro Data Center

An on-premise data center cabinet with touch screen monitoring. Includes power, cooling, management and security.



PRODUCT OVERVIEW

The EdgeRack 3P Series Secure Integrated Cabinet is a fully integrated enclosure that provides power, cooling, management, and security in a small footprint. Equipped with 3.5kW of cooling, power management (3kVA of output power via the UPS), environmental sensors, remote monitoring, and intuitive controls, the 3P comes with a fully integrated monitoring environment for all the cabinets sensors--temperature, humidity, smoke detection, and leak detection.

PRODUCT APPLICATIONS

- SMALL TO MID-SIZED OFFICES
- EDUCATIONAL INSTITUTIONS
- REMOTE OR BRANCH OFFICES
- MEDICAL FACILITIES
- RETAIL STORES
- IT TEST LABS
- CLEAN ROOM ENVIRONMENTS

PRODUCT APPLICATIONS

- Top-mounted, self-contained cooling unit with efficient variable frequency technology for managing up to 3.5kW of cooling capacity
- Integrated monitoring system with HMI touch-screen for intuitive system management and monitoring
- Power control module with breaker panel for precise power management and protection
- Electro-magnetic, auto-opening door system forces the doors open in emergency high-heat and power outage situations
- Magnetic, movable temperature / humidity and smoke detection sensors for monitoring your enclosed environment
- Water leakage detection cord at the bottom of the unit to quickly alert you to any moisture risks
- Front plexiglass door and split metal rear doors with smart locks provide a secure solution for your IT equipment
- Locking side panels for quick side access and added security

EDGERACK 3P SERIES SOLUTION BENEFITS



Smart Cabinet Solution: The entire IT Infrastructure (network, storage, and computing) can be housed in one enclosed cabinet that works in traditional and non-traditional IoT spaces. A fully integrated design that lets you load your equipment and go.



Plug and Play: The built-in, prefabricated, and pretested system has an integrated cooling unit and condensate water processing unit, allowing you to quickly and easily achieve deployment within hours.



Integrated Highly Efficient Cooling: An integrated 3.5kW top-mounted cooling unit efficiently cools your IT equipment by delivering a curtain of cold air down the front of your cabinet. It protects your sensitive electronics without the need for an outdoor condenser.



Increased Equipment Efficiency & Heat Reduction: The smart cabinet's enclosed system, well-insulated cooling aisle, and up to 3.5kW cooling unit with an inverter compressor and EC fans provide highly efficient protection for your sensitive IT equipment.



Enhanced Security: All of the doors and side panels have locking features, creating a secure environment for your critical IT Systems. Enjoy maximum protection with an intelligent magnetic lock that protects your equipment when outages or cooling failures occur.



Reduced Footprint: Save space by consolidating and securing IT equipment in a single cabinet footprint without an outdoor cooling unit.



Integrated Management: Built-in monitoring system with a touch screen user-interface makes it easy to view, receive notifications and control the units running status. The system monitors, controls, and provides alerts on all hardware in the cabinet including the UPS, air conditioning unit, temperature and humidity sensors, and more.



Smart-Sensing: Temperature and humidity, smoke, and leak detection sensors are included to help you monitor your enclosed environment.



Power Management: The included power distribution module provides power-line protection and management, UPS service by-pass (for application with UPS and battery installed), surge protection, and power metering.



HMI FEATURES

- TOUCH-SCREEN
- EQUIPMENT MONITORING
- POWER MONITORING
- TEMPERATURE AND HUMIDITY MONITORING
- SMOKE DETECTION
- LEAK DETECTION

COMPLIANCE/STANDARDS	SPECS
Safety Compliance	CE-LVD
EMC Compliance	CE-EMC, FCC
Environmental Compliance	RoHS, REACH
IP Rating	IP5X

EDGERACK 3P SERIES SECURE INTEGRATED CABINET SCHEMATICS WITH ACCESSORIES

The Enconnex 3P Series Secure Integrated Cabinet has many standard accessories included with your build. Take a look below.

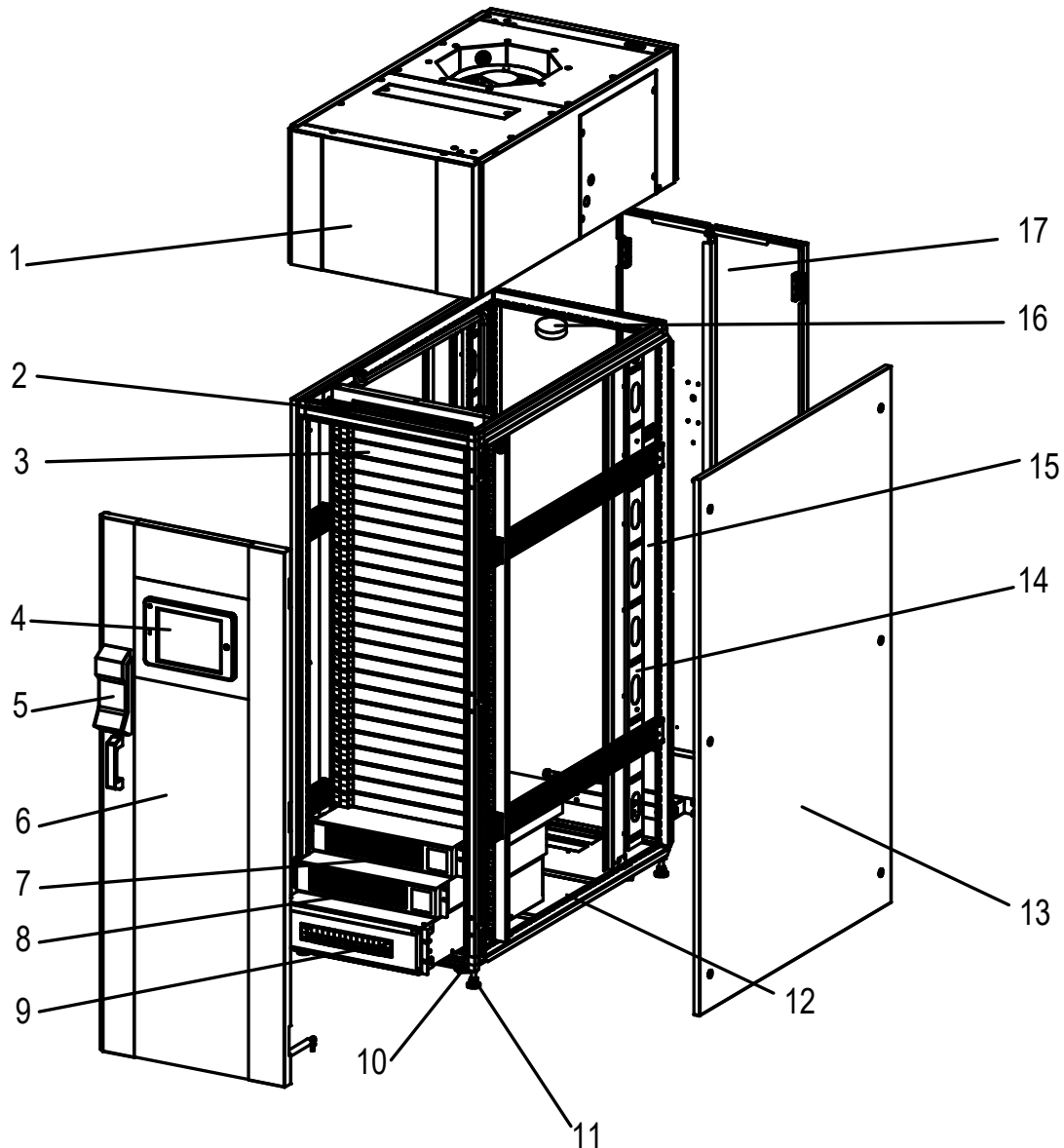

- | | | |
|------------------------------|------------------------------|------------------------|
| 1. Cooling Unit | 7. UPS | 13. Cabinet Side Panel |
| 2. Temp and Humidity Sensor | 8. Battery | 14. Cable Tray |
| 3. Blanking Panel | 9. Power Distribution Module | 15. PDU |
| 4. Integrated HMI Screen | 10. Casters | 16. Smoke Sensor |
| 5. Access Control | 11. Leveling Feet | 17. Steel, Split Doors |
| 6. Double-Layered Glass Door | 12. Water Leakage | |

PHYSICAL SPECIFICATIONS

Physical	Specs
Cabinet Dimensions (HxWxD)	2025 x 600 x 1100 mm
Net Weight	330 kg
Cabinet Dimensions - Shipping (HxWxD)	2180 x 710 x 1210 mm
Shipping Weight	374 kg
Max Load Capacity	1360 kg
Available Unit Height	26U
Cooling Unit Dimensions (Top Mount) (HxWxD)	389 x 600 x 1100 mm
Site Positioning	2.5" heavy-duty castors and leveling feet
Input Voltage	208V - 240V
AC Frequency	50Hz and 60Hz



COMPONENT ATTRIBUTES

Component	Specs
Front Door	Front Glass Plus Plexiglass Door with Smart Lock (1 pcs)
Rear Door	Rear Split Solid Doors (1 pcs) with Smart Lock (1pcs)
Side Panels	Solid Side Panels with Insulation Material (4 pcs)
Cooling Unit (Top Mount)	3.5kW Cooling Capacity (1 pcs)
UPS	3.0kVA Power Output with Internal Batteries (1 pcs)
AC Frequency	50Hz & 60Hz
Input Voltage	208V - 240V
Power Distribution	16A/20A Inputs and Power Control Unit (1 pcs)
Cable Management Bar	Vertical Bar (2 pcs), Horizontal Bar (1 pcs)
LED Indicators (red/blue)	(Front LED 1 Red pcs) & (Rear LED 1 Blue pcs)
Environmental Sensors	Leak Detection Sensor (1 pcs)
Environmental Sensors	Temperature and Humidity Sensor (1 pcs)
Environmental Sensors	Smoke Detection Sensor (1 pcs)
Monitoring	HMI with Monitoring Controls (1 pcs)
Cable Entry Access	Bottom with Brushed Entry at Rear (1 pcs)
Security	Electro-Magnetic Door Opening & Locking System (2 pcs)
Cooling Unit Noise Level	Normal Running Conditions 62dBA @1m