

THIS DRAWING AND SPECIFICATIONS HEREIN ARE THE PROPERTY OF ENCONNEX LLC. AND SHALL NOT BE COPIED, REPRODUCED OR USED IN WHOLE OR IN PART, AS THE BASIS FOR THE MANUFACTURE OR SALE OF ITEMS WITHOUT THE WRITTEN PERMISSION OF ENCONNEX LLC. THIS DRAWING IS SUBJECT TO CHANGE WITHOUT NOTICE.

REVISIONS				
REV.	SUFFIX	DESCRIPTION	DATE	APPROVED
A		Full Release	2020-06-18	FANCY FAN

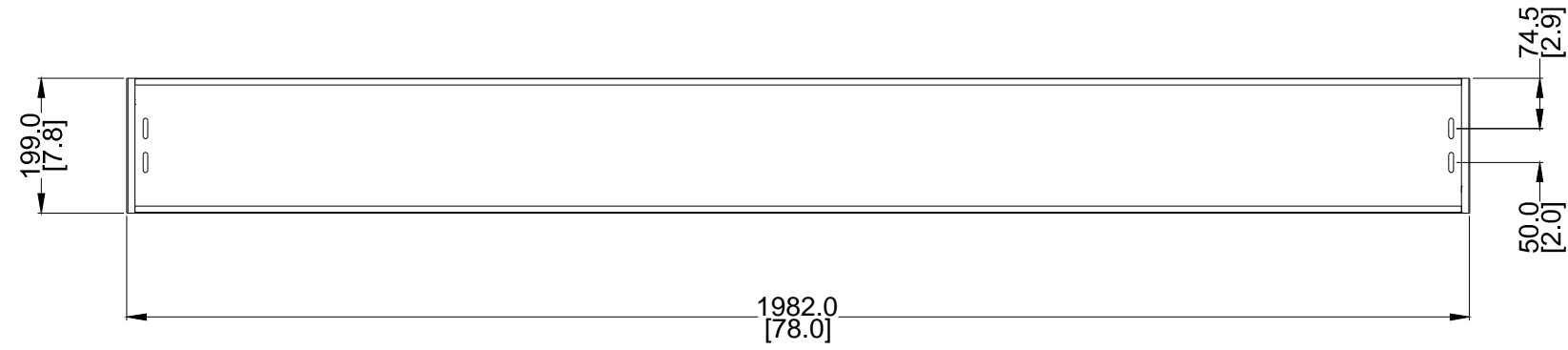

TOP VIEW

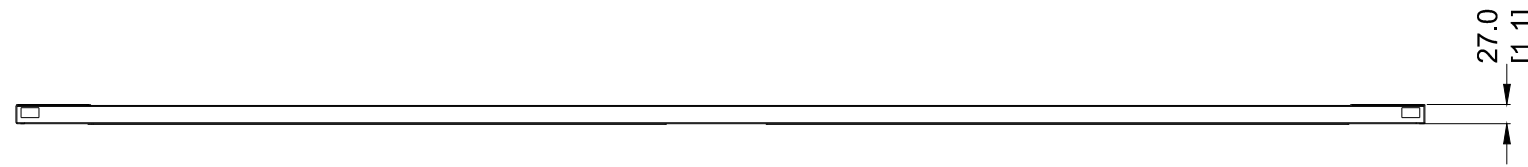

FRONT VIEW

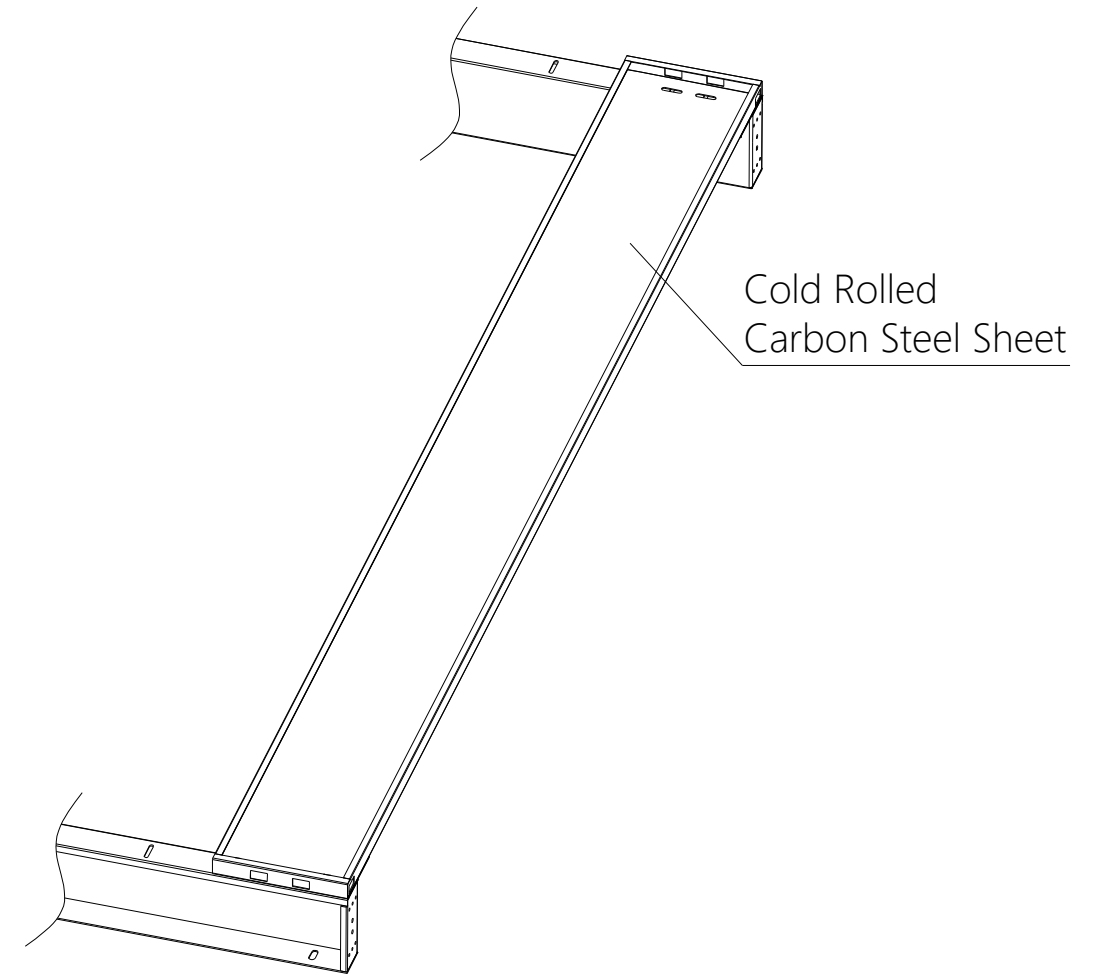

NOTES, UNLESS OTHERWISE SPECIFIED:

- MATERIAL: CRS
- FINISH: RAL9005 TEXTURE POWDER COATING
- PART MUST BE SUFFICIENTLY FREE OF BURRS AND SHARP EDGES TO PASS UL 1439 SHARP EDGE TEST.
- 3D CAD AVAILABLE IN ADDITION TO PDF PRINT. SHOULD DISCREPANCY ARISE, CONSULT ENCONNEX ENGINEERING IMMEDIATELY.
- ALL PARTS TO BE FREE OF DIRT OR GRIME THAT PREVENTS LABEL ADHESION OR ALLOWS TRANSFER ONTO COSMETIC AREAS.
- MUST BE ROHS COMPLIANT, INCLUDING HARDWARE. IF CONFLICTING SPECIFICATIONS EXIST, CONTACT ENCONNEX ENGINEERING.
- DIMENSIONS IDENTIFIED WITH (X.XX) ARE CONSIDERED CRITICAL TO QUALITY (CTQ) DIMENSIONS. THESE DIMENSIONS ARE EXPECTED TO BE MONITORED STATISTICALLY AND DOCUMENTED AS PART OF THE FABRICATION PROCESS.

UNLESS NOTED, DIMENSIONS IN MILLIMETERS & TOLERANCES ARE: X. ±1 MM X° ±1° X.X ±0.5 MM X.X° ±0.5° X.XX ±0.20 MM ØX.X ±0.3 MM ØX.XX ±0.10 MM		 4670 AIRCENTER CIRCLE, RENO, NV89502	PRODUCT LINE: Containment Fixed Ceiling Tile
DRAWING FILE NAME ECX-218-FXD-CLG-001 3D MODEL FILE NAME ECX-218-FXD-CLG-001 3D MODEL CONFIGURATION Default			ENGINEER: FANCY.FAN
THIRD ANGLE PROJECTION		ITEM WEIGHT (REFERENCE ONLY)	REV: A
UNITS:MM(IN)	INTERPRET TO ASME Y14.100	SIZE: B	SCALE:N/A DO NOT SCALE DRAWING SHEET: 1/1

PART NUMBER: ECX-218-FXD-CLG-001	DESCRIPTION: 200mm x 1800mm (6ft) Fixed Ceiling Tile
-------------------------------------	--